

BRASS CABINET HANDLES

	6502	6503	6504
Product codes:	6508	6509	6510
	6514	6515	6516

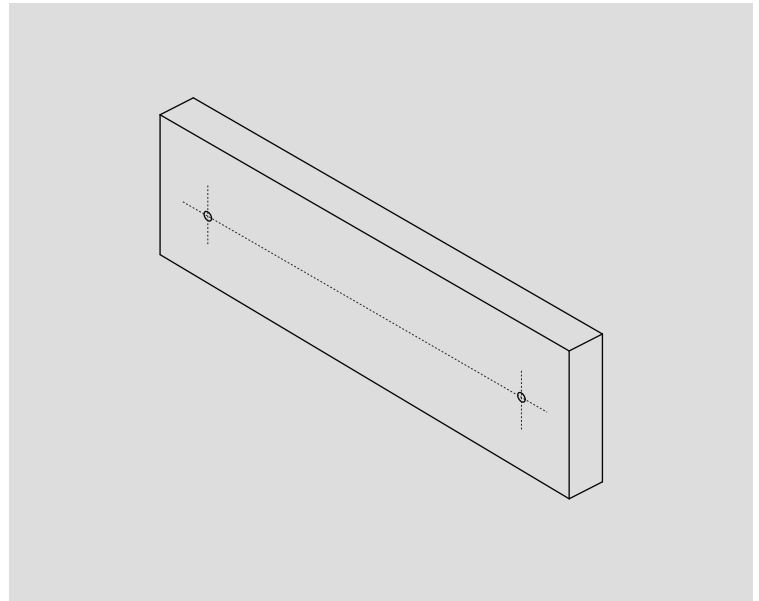
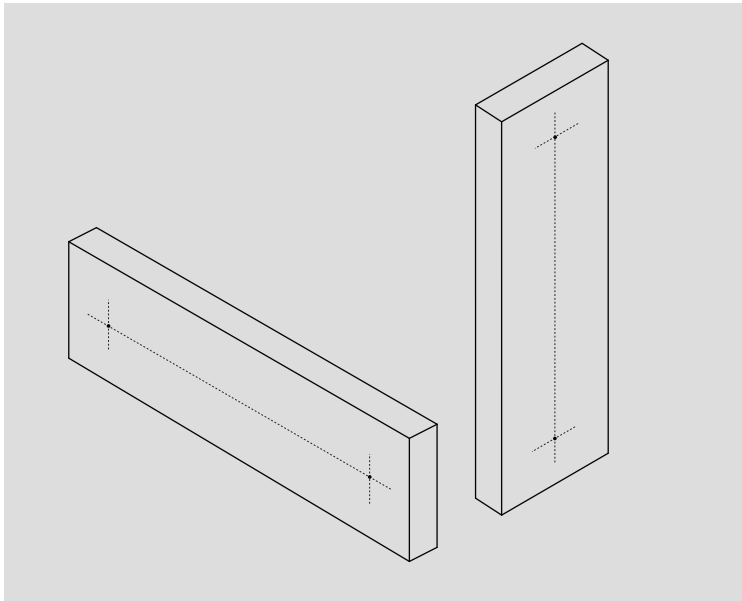

- Includes:**
- 1x Cabinet Handle
 - 2x M4 Screws*
 - 2x Washers
 - 2x Mounting Plates (optional)

1. Mark the fixing position for the cabinet handle on the door/drawer. They can be installed horizontally or vertically depending on the desired look.

Ensure adequate space is provided for clearance of knuckles when opening cabinetry.

2. Drill two 5.5mm diameter holes at the marked fixing positions for the leg centres.

160mm Handles

6502, 6508, 6514 - 130mm crs

260mm Handles

6503, 6509, 6515 - 230mm crs

360mm Handles

6504, 6510, 6516 - 330mm crs

* non standard cabinet thicknesses may require longer screws.

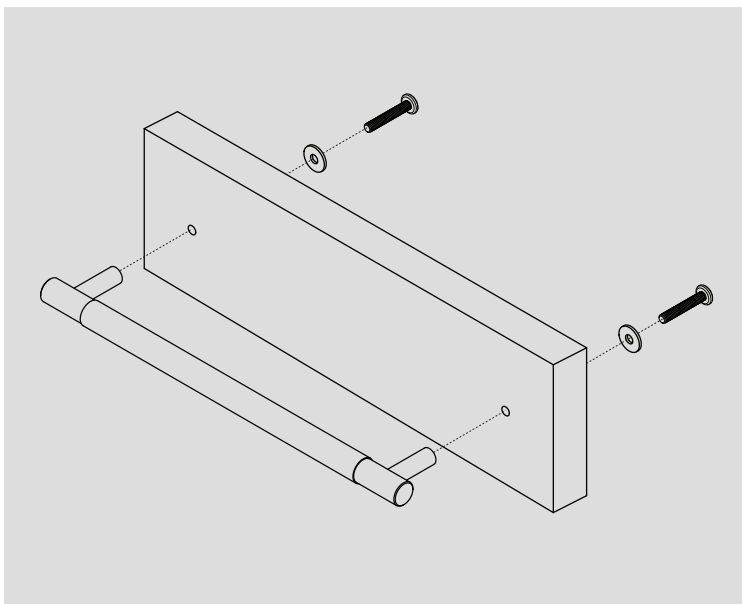

3. Hold the cabinet handle up so the legs align with the pre-drilled 5.5mm diameter holes.

Thread the screw through the washer, then the cabinet front, into mounting discs (if including) or backing plates* finishing with the legs of the cabinet handles. Repeat with the other leg.

Tighten the screws by using a screwdriver to fix them in position.

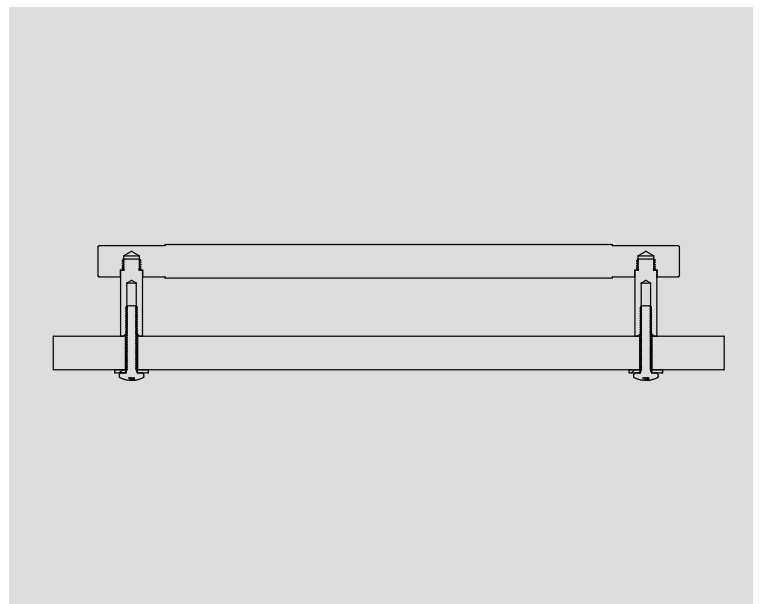

4. Ensure that you do not overtighten the screws. The washers should not bite in.

Backing Plate Codes

6526 - 160mm

6527 - 260mm

6528 - 360mm

* For retro-fitting backing plates can be ordered separately see product codes below step 4.