

SMART ENTRY



Windsor
ARCHITECTURAL HARDWARE

INSTALLATION &
PROGRAMMING GUIDE

THE CONTENTS



Fitting Instructions **2**

Set Up **8**

Download App	9
Account Set Up and Registration	10
Creating Your Home	12
Connecting Lock and App via Bluetooth	14
Connecting Wi-Fi Bridge to Your Phone	16
Connecting Lock to the Wi-Fi Bridge	18
User Code and Swipe Card	20
Add and Manage Other Users	22

Using the App **24**

User Interface Introduction	25
Lock and Unlock — App, Keypad, Card or Key	26
My User 'Me' Overview	27

Bonus Features **28**

Dynamic Code	29
Automatic Lock Switch	30
Using Passage Mode	32
Opening Record	33
One Time Code	34
Periodic Code	36
Changing Home Roles	38
Removing Devices	40
Factory Resetting Device	40

Frequently Asked Questions **41**

FITTING INSTRUCTIONS

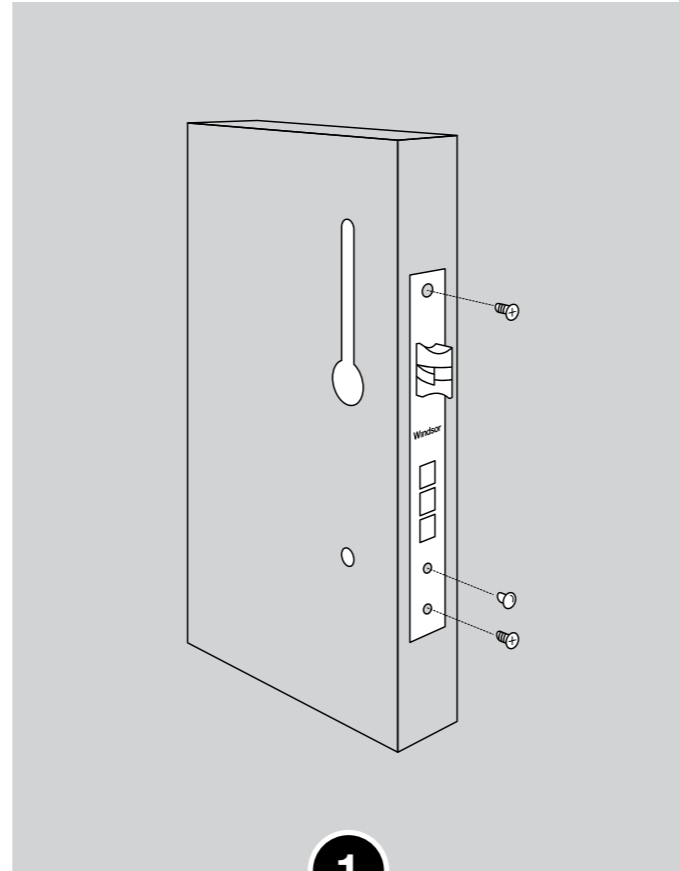
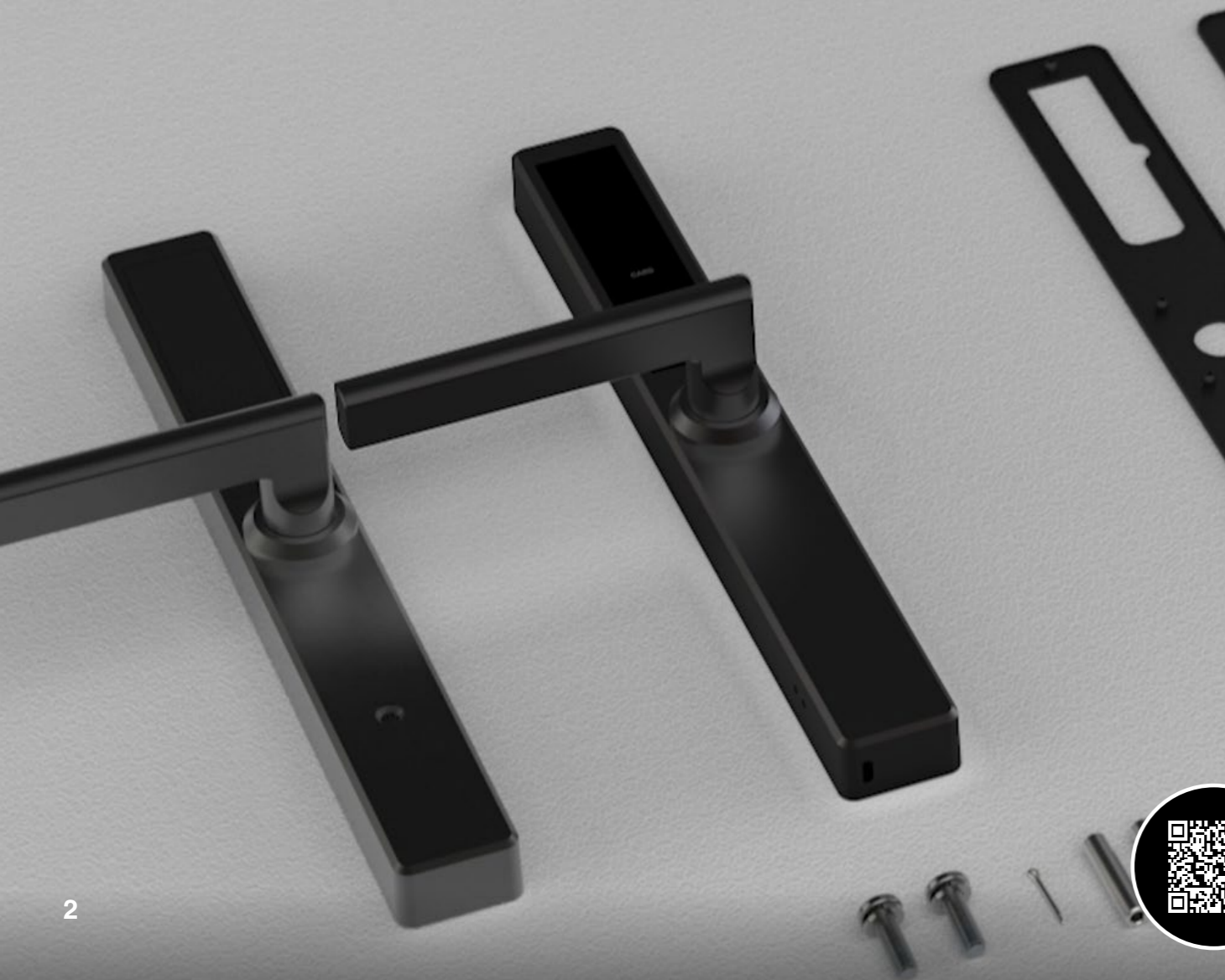

1

- a. Insert the mortice and fix with the two wood or aluminium screws provided into the top and bottom holes.
- b. Insert the black bung into the middle hole.



Scan me to watch a video of the fitting instructions

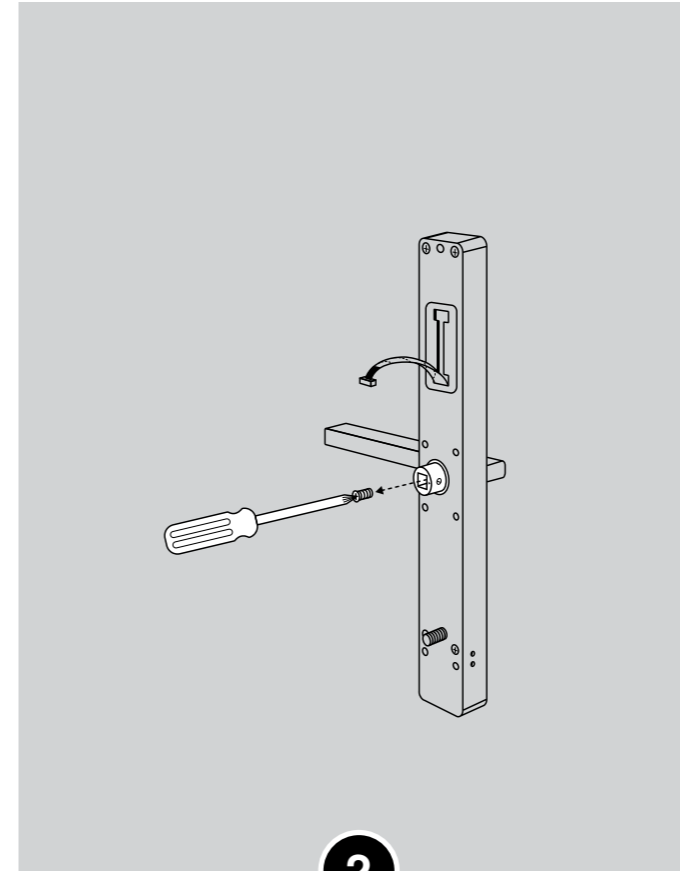

2

- a. Remove the temporary screws from the back of each handle.
- b. Ensure the lever is handed to suit your door, the lever should be pointing towards the hinges.
- c. If the default handing is suitable for your door proceed to step 4 on the following page.

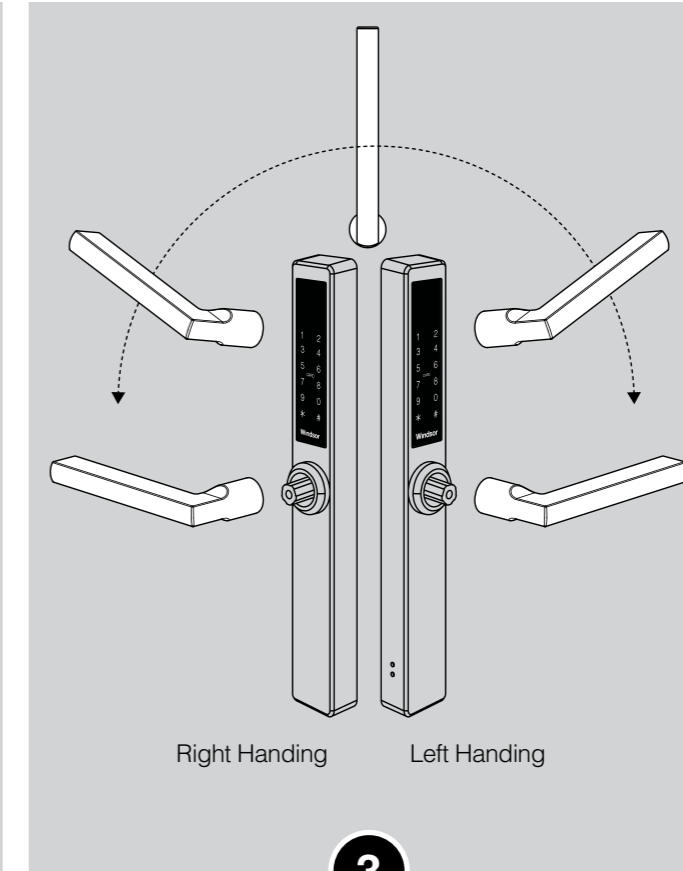

3

- a. If you need to adjust the handing, remove the handle from the lock body and flip the lever so it is pointing towards the hinges of your door.
This will need to be done for both the front and back units.

Package Contents

Part	Description	QTY
A	Front Panel	1
B	Back Panel	1
C	Mortice Lock	1
D	Striker & Dustbox	1
E	Cards	3
F	Mechanical Keys	2
G	Rubber Seals	2
I	Split Pin	1
J	Sliding Threaded Sleeves 35x8mm	2
K	Sliding Screws 16x5mm	2
L	Mortice Screws 10x5mm (for aluminium doors)	4
M	Mortice Screws 25x4mm (for wooden doors)	4
N	M5x25mm Screw	1
O	M5x30mm Screw	1
P	M5x40mm Screw	1
Q	M5x50mm Screw	1
R	M5x70mm Screw	1
S	Spindle for door thicknesses 30-55mm	1
T	Spindle for door thicknesses 45-70mm	1

Product Measurements

Mortice Locks			
Code	Backset	Case Height	Case Depth
1520	30mm	174mm	45mm
1521	35mm	174mm	50mm
1522	45mm	174mm	60mm
1523	60mm	174mm	85mm
1525	35mm	218mm	48mm

Lever Styles				
Code	Body Height*	Body Width*	Lever	Protrusion*
1501	310mm	40mm	130mm	78mm
1511	310mm	40mm	73mm	78mm
1512	310mm	40mm	73mm	78mm
1513	310mm	40mm	130mm	78mm

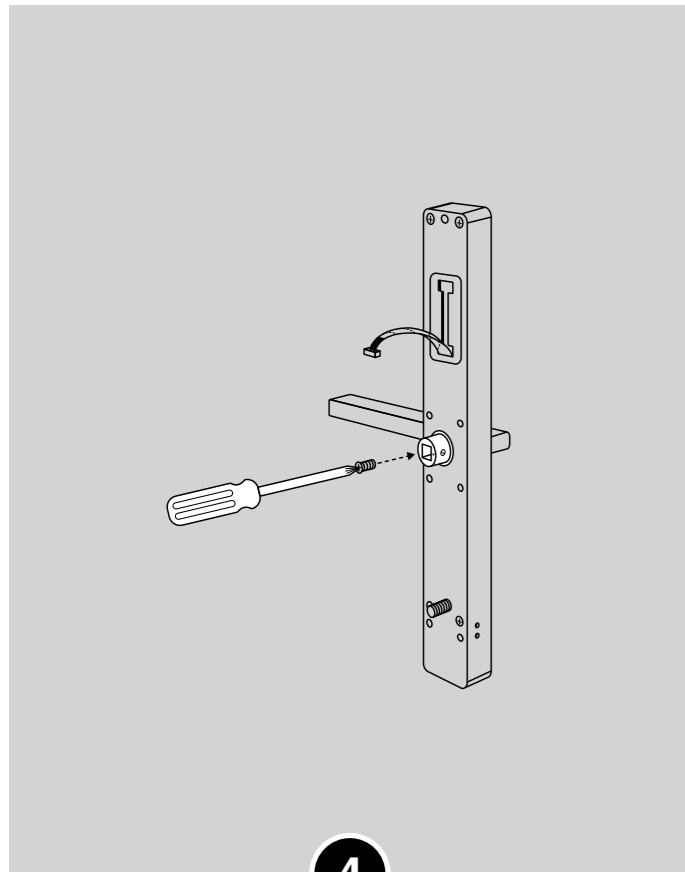

4

- a. At the back of each handle, secure the levers with the provided M5 screws coated in blue Loctite on the thread.

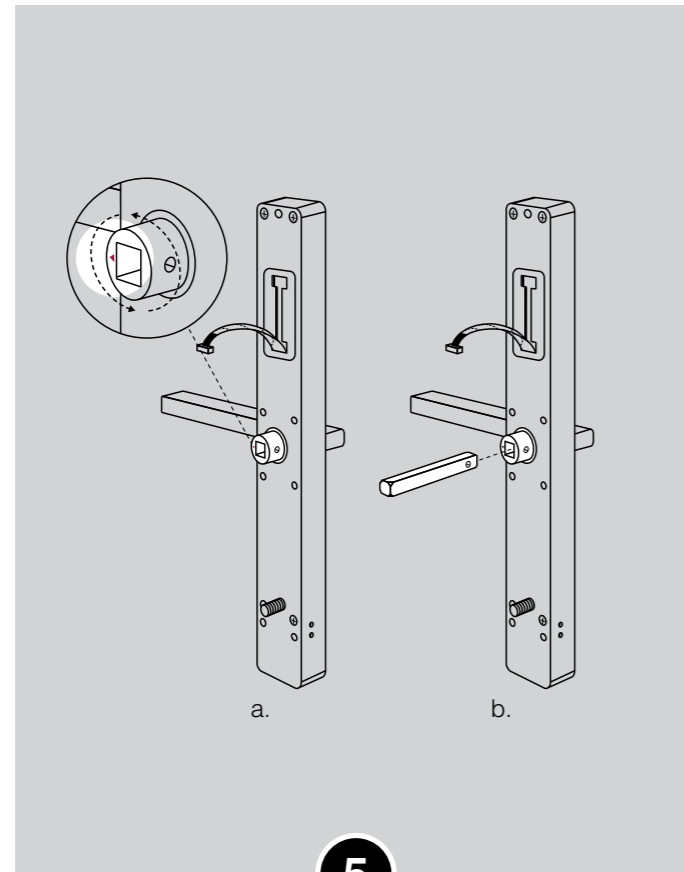

5

- a. On the front lock body, ensure the small arrow on the spindle shaft is pointing to the hinges — **this is especially important if you have changed the handing of your lever.** Refer to green sticker on the back of the front lock unit.
- b. Select which size of the provided spindles is suitable for your door thickness. Insert the chosen spindle into the back of the lever, the end with the through holes should align with the holes in the spindle shaft.

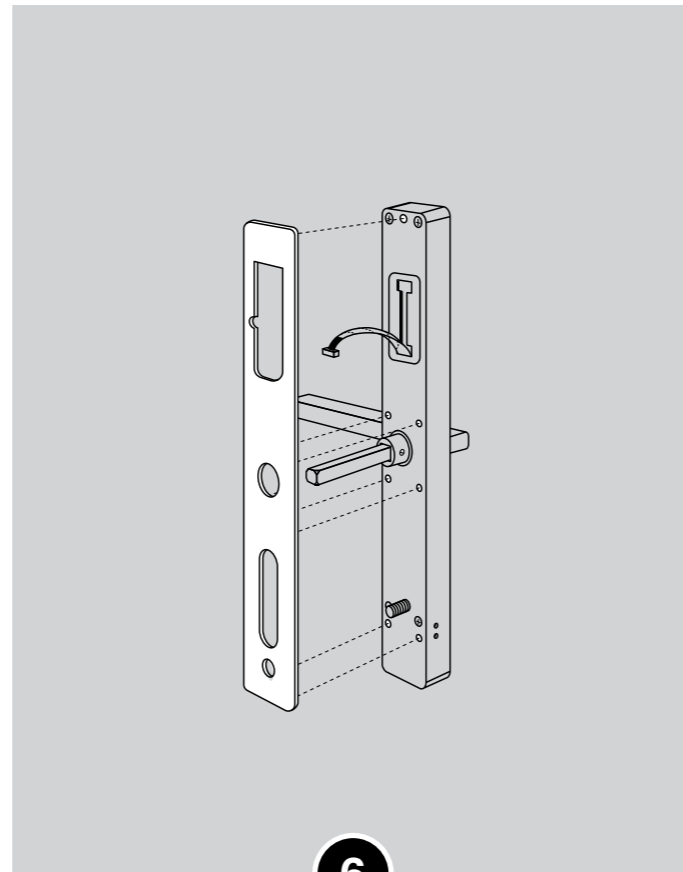

6

- a. Attach the black rubber seals onto both units, clipping the rubber nodules into place.

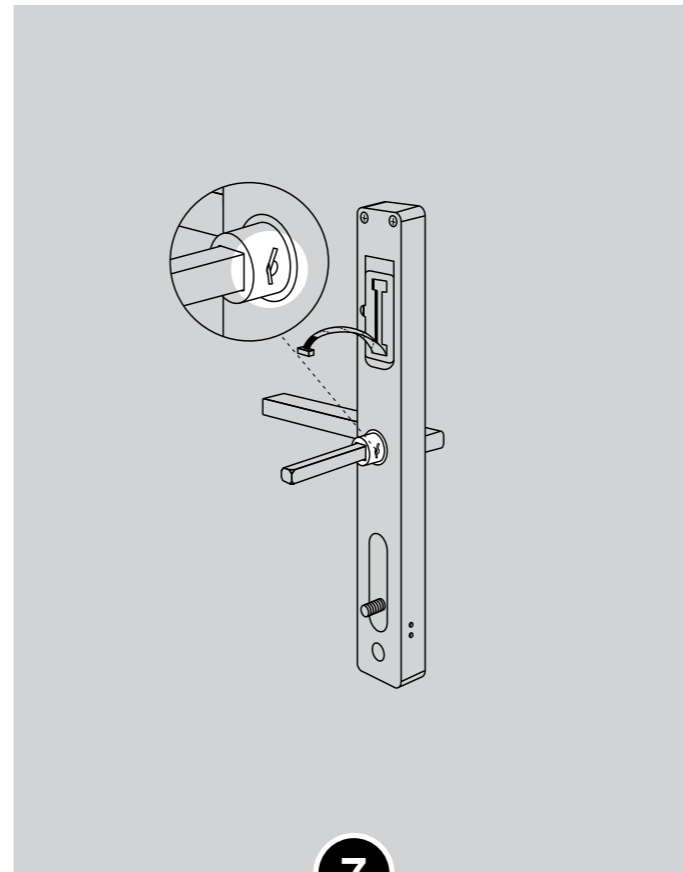

7

- a. Insert the split pin through the hole in the spindle and shaft and then splay ends to ensure the spindle does not fall out.

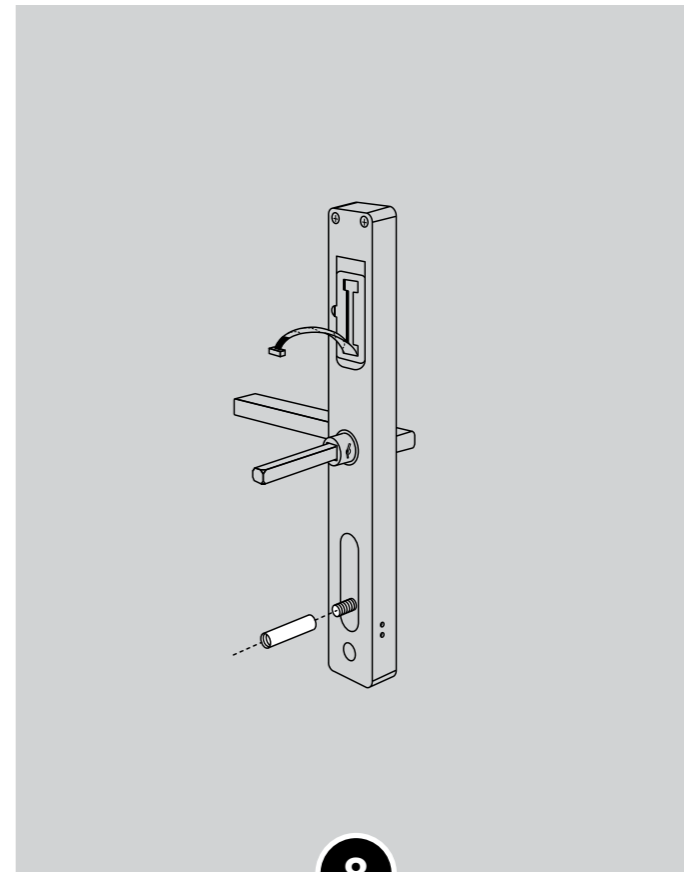

8

- a. Staying on the front lock unit, fit a threaded sleeve to the bottom spigot and tighten. Ensure the indented end is fitted at the base.

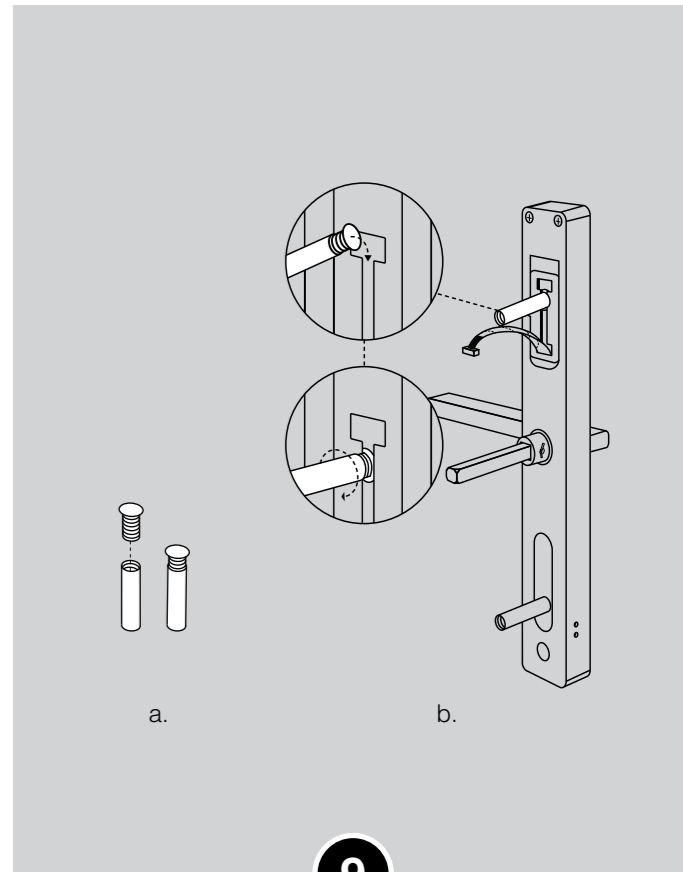

9

- a. Screw the blank sliding screw into the other threaded sleeve, leaving 3mm of the screw head proud.
- b. Insert the threaded sleeve into the top T shaped cut out by tilting it into place. It should then freely slide so you can adjust the height depending on the mortice hole drilling (between 55–100mm from the center of the spindle shaft). Once in position tighten.

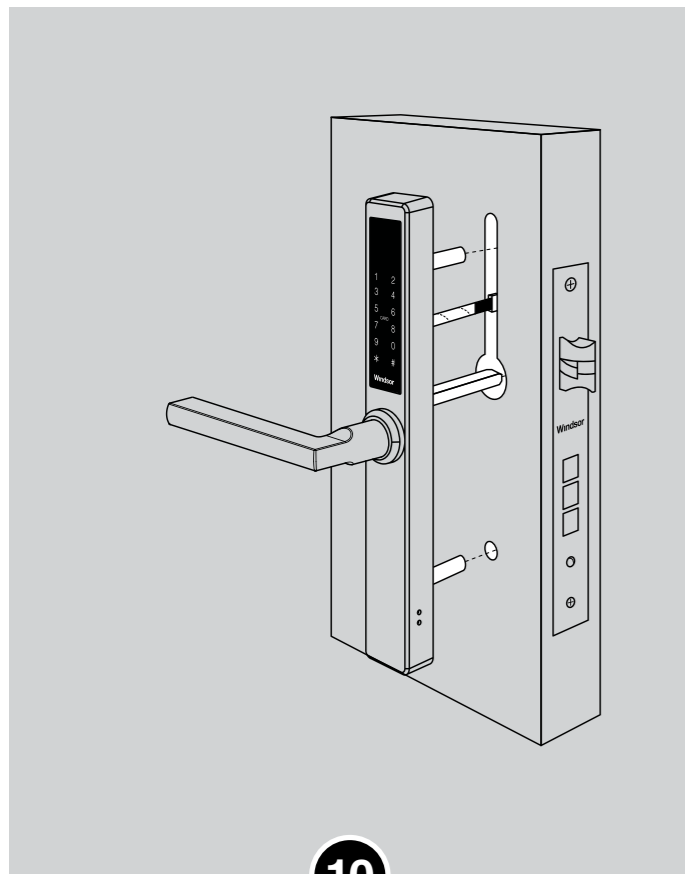

10

- a. Hold the front unit up to the door, then feed the cable, spindle and threaded sleeves through their respective cut outs.

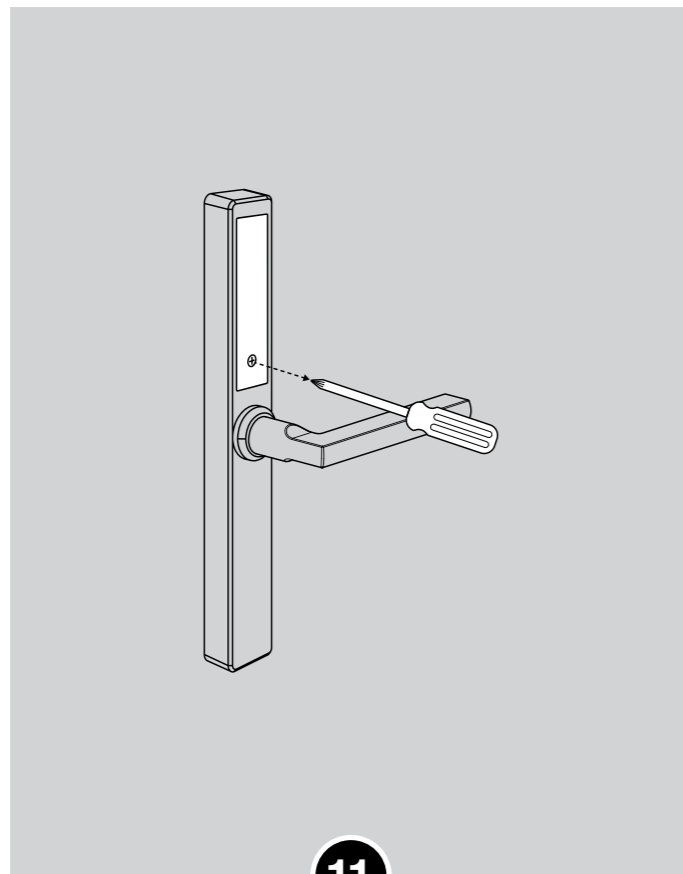

11

- a. Unscrew the battery cover of the rear unit and set aside.

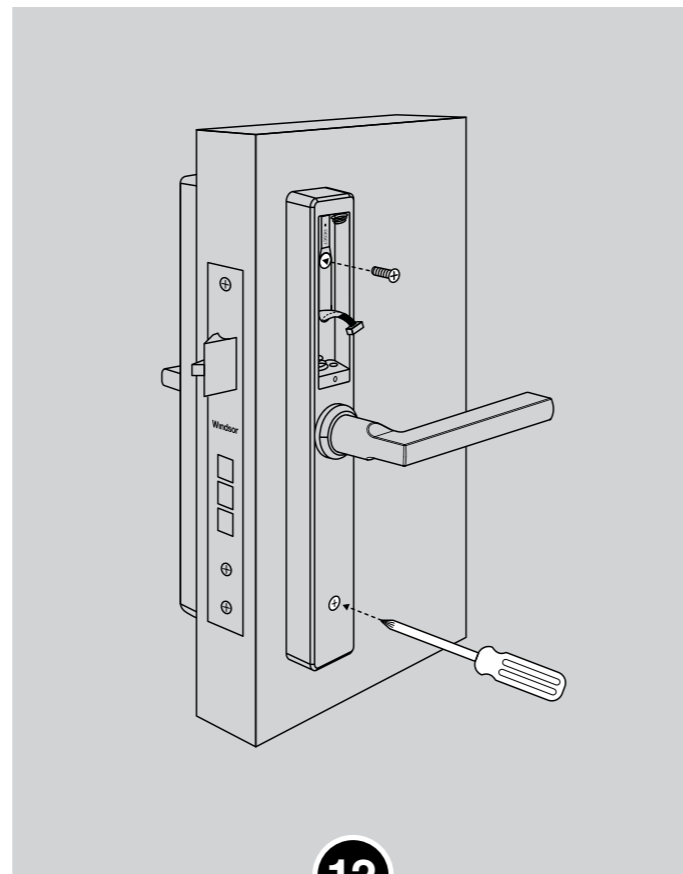

12

- a. Ensuring both units are sitting straight on the door, hold firmly and secure the rear unit by tightening the screws into the threaded sleeves of the front unit.

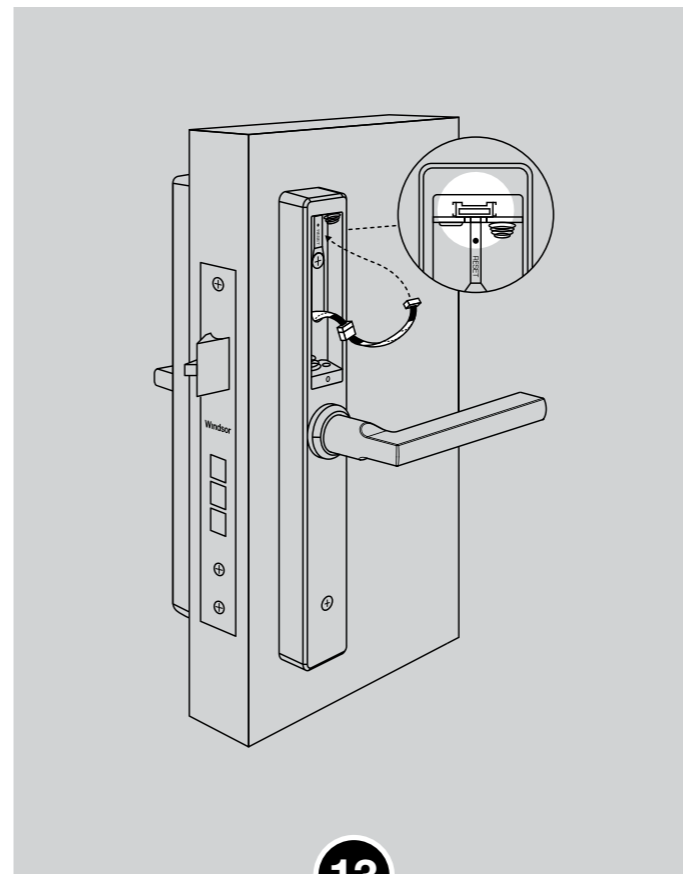

13

- a. Connect cable extender and insert it into the cable port at the top of the rear unit.
b. Push any excess cable back through the door cavity to clear from battery bay.

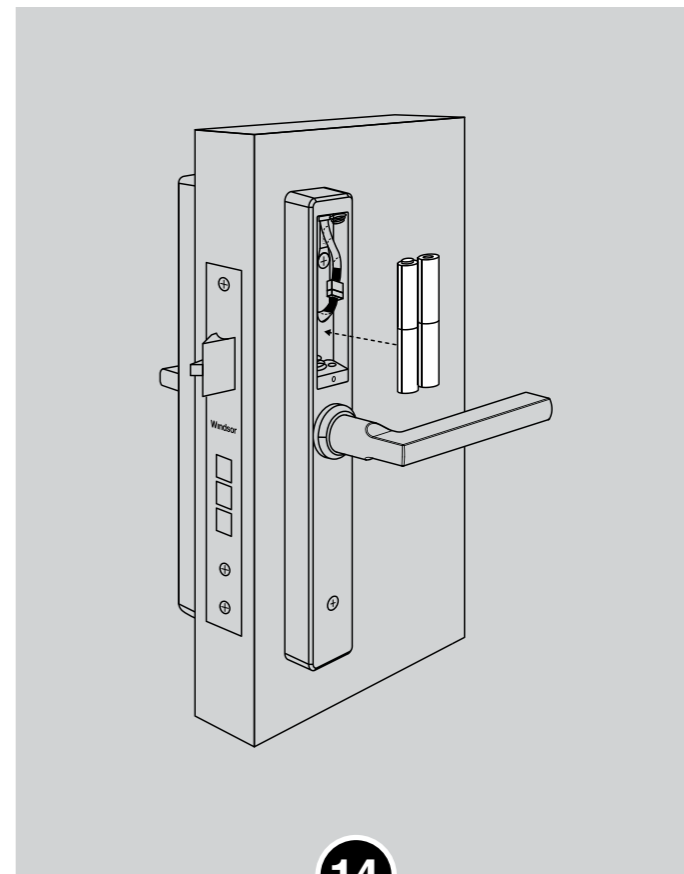

14

- a. Insert the 4x AA alkaline batteries* (lock will chime to confirm it has been installed correctly).

* Warranty void if alkaline batteries are not used.

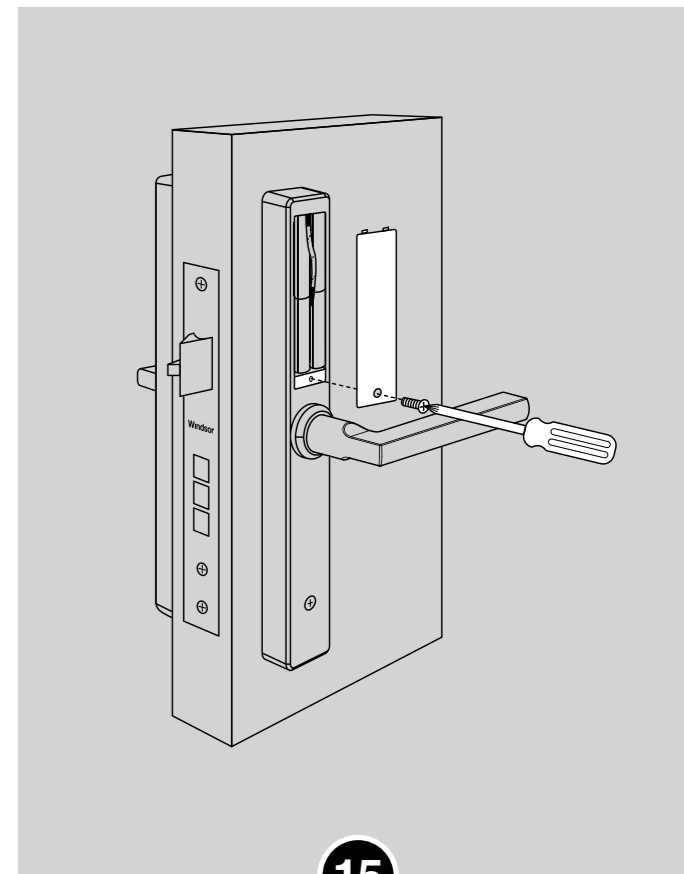

15

- a. Reattach the battery cover and secure with screw provided.

You are now ready to programme your lock. Please follow steps carefully and in chronological order.

> Note: for instructions on how to reset the lock to factory settings refer to pg. 38.



SET UP

Download App

Whether you wish to control your Windsor Smart Entry independently or integrate with an existing smart home, the choice is yours.

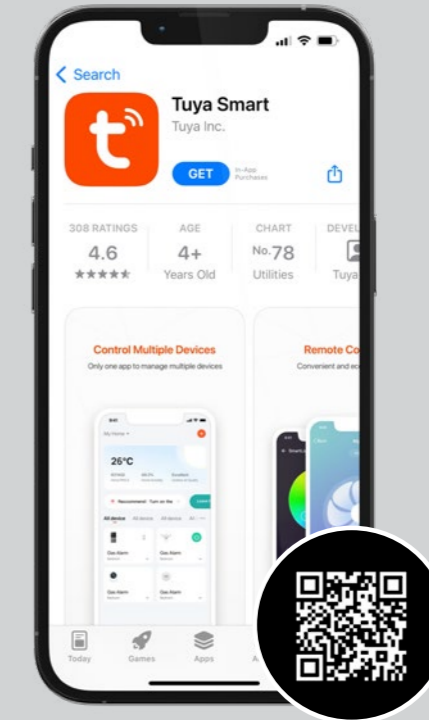
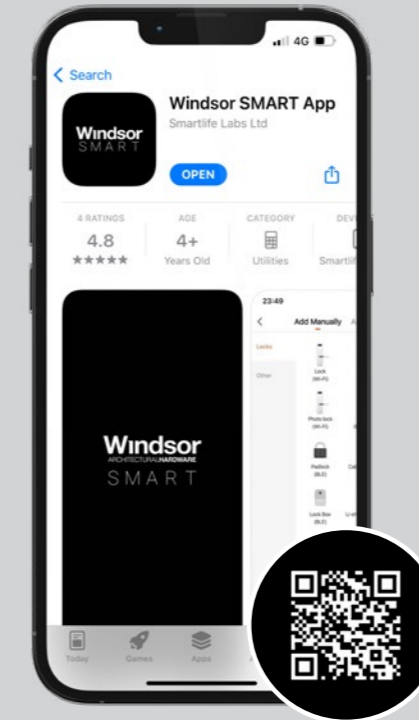

INDEPENDENT INSTALLATION*

Download the black 'Windsor SMART' app by either scanning the QR code above or searching on Google Play or the Apple App Store.

SMART HOME INSTALLATION*

Download the 'Tuya Smart' app by either scanning the QR code above or searching on Google Play or the Apple App Store.

- > *Note: if you wish to connect your Windsor Smart Entry to a smart home system for example Google Home or Amazon Alexa, you will need to purchase the Windsor Wi-Fi Bridge.*

Once the chosen app installation is completed, turn on the device's Bluetooth and open the chosen app to begin pairing.

- > *Note: your Bluetooth must remain on while using the app.*
- > *Note: the following instructions are applicable for both apps.*

* Some older mobile phones may not be compatible with the app(s).

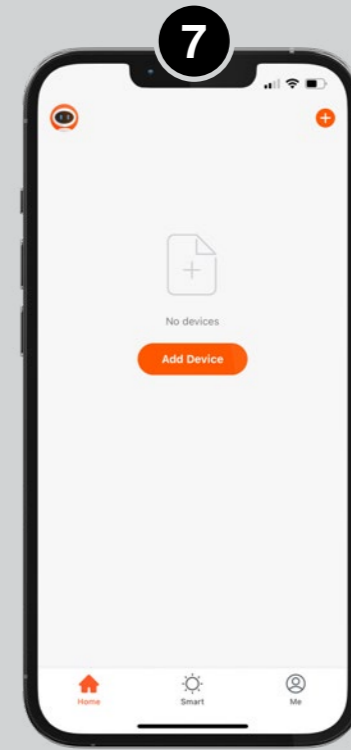
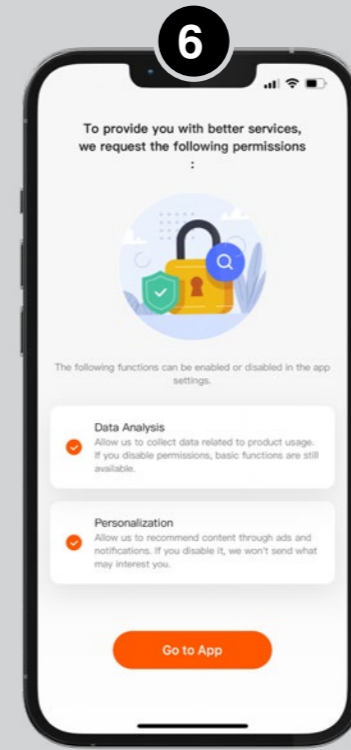
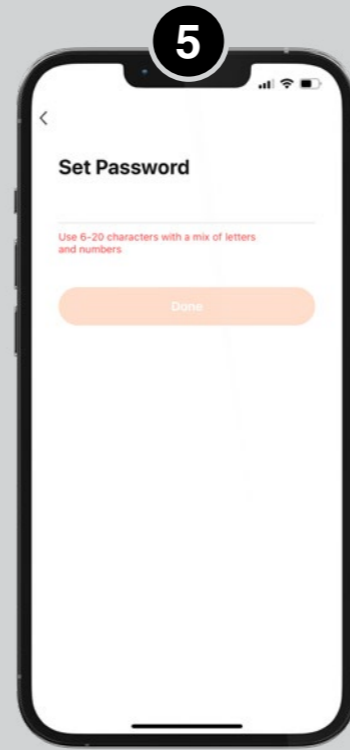
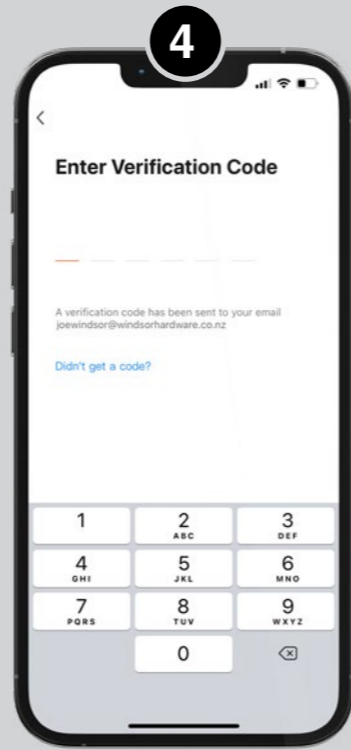
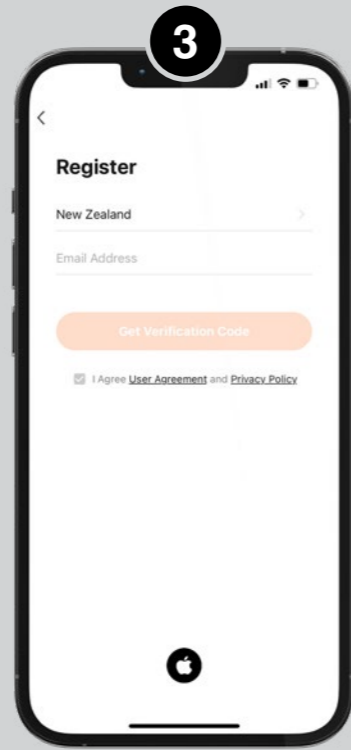
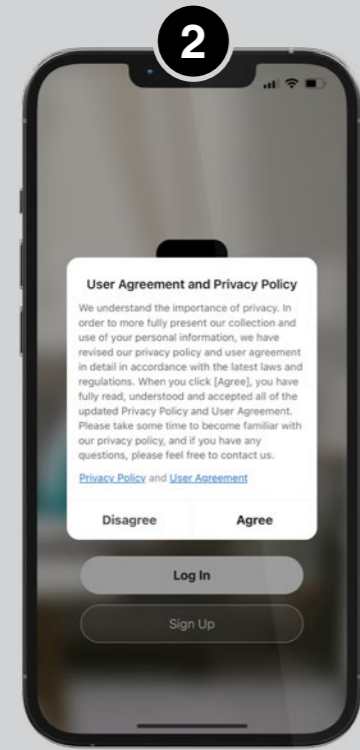
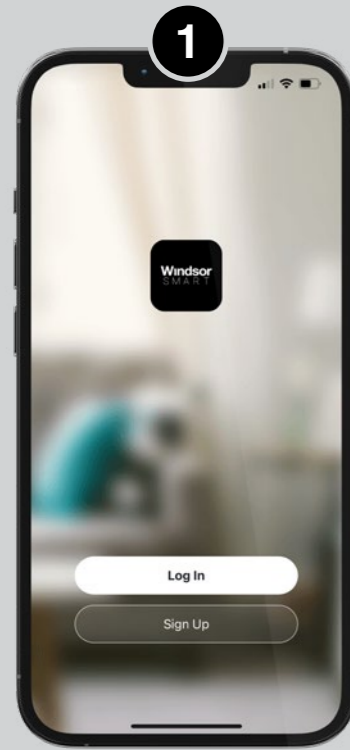

1. To register open the app and select 'Sign Up.'

2. Please read and acknowledge the User Agreement and Privacy Policy before continuing the registration.

3. Register your location and sign up with a valid email address and select 'Get Verification Code.'

4. Input the verification code sent to your nominated email address.

5. You will automatically be prompted to set a password.

› *Note: please ensure you keep your password and login details safe. However, if you do forget these, you can reset your password simply through your email verification.*

6. Review the permissions required and select 'Go to App.'

7. You are now successfully logged in to the Windsor SMART app.

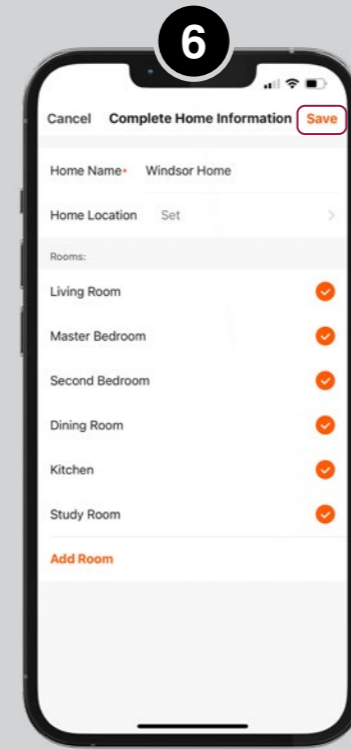
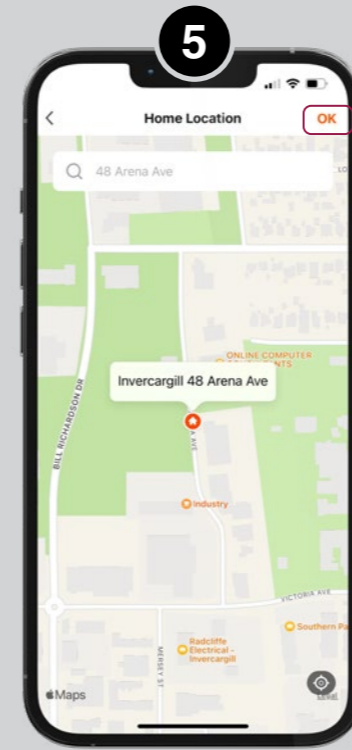
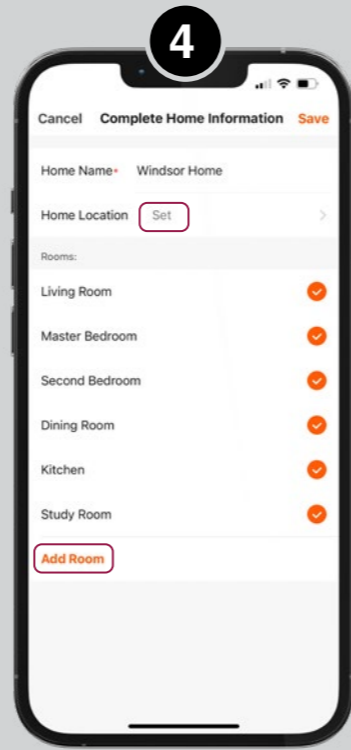
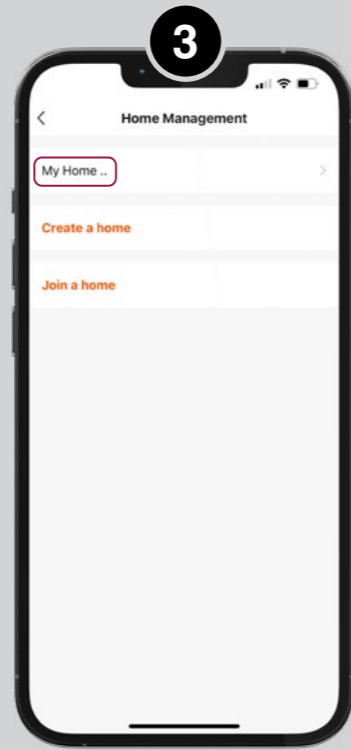
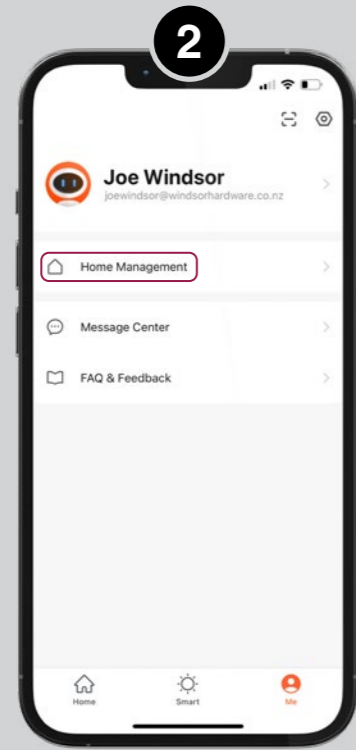
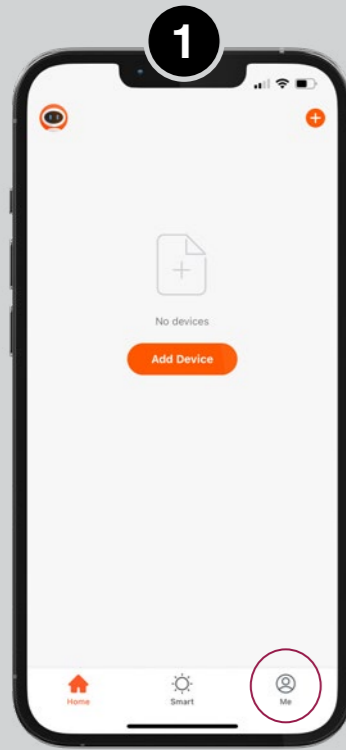

1. In the main home screen of the app select 'Me'.

2. Select 'Home Management'.

3. Select the default home titled 'My Home'.

- > Create a Home: You would select this if you are setting up a lock at another premise e.g Airbnb.
- > Join a Home: You would select this if you are attempting to join an existing home that has already been set up e.g. family member.

4. Identify where the lock will be installed. Deselect any rooms where you have not installed a lock.
Select 'Add Room' and enter the location(s) of the lock(s) e.g. Front Door and/or Garage.
Then you **must** set your home location by selecting 'Set'.

5. Once you have named your home confirm the location on the map — this should automatically locate you, if not, scroll on the map to find your location. Then select 'OK'.

- > *Note: you can enter your address if you cannot find it on the map.*
- > *Note: this location information is secure to your login and is not accessible by Windsor.*

6. Now select 'Save' to complete your home set up.

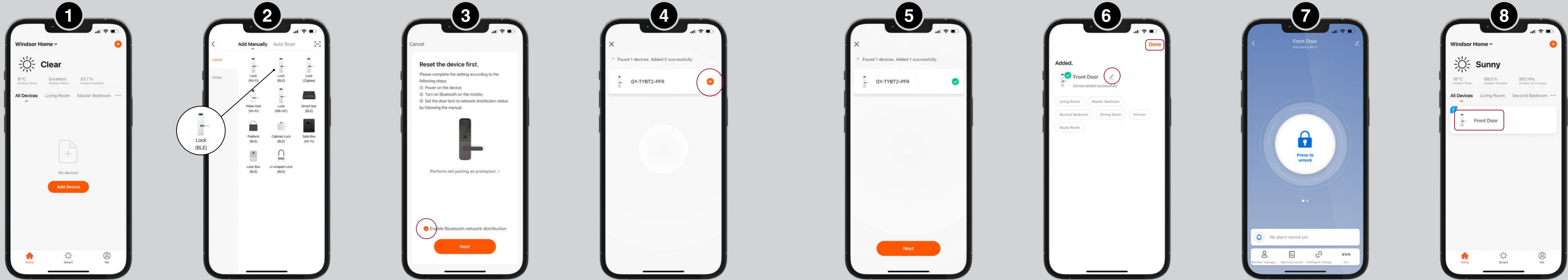

1. In the main home screen select 'Add Device'.
 > *Note: to add more locks or devices to your app, select the '+' in the top right corner of the app home page.*
2. In the list of devices select 'Lock BLE'.
3. You must complete a start-up reset on your device first. To do this press '8' then '#' on the lock keypad — the voice guide will say 'Activation Mode Engaged'.
 Select the tick box 'Enable Bluetooth Network Distribution' then select 'Next'.
4. Once the device shows up, select the '+' and stay near the lock while it connects. This may take up to 30 seconds.
5. Once the green tick appears, the lock has been successfully connected. Then select 'Next'.
6. You are now able to rename your lock by selecting the pen icon. Then select 'Done'.
7. The app will then show a blue screen — this is the lock's home screen. From here you can manage all the functions of your lock.
 > *Note: refer to pg. 25 for the user interface introduction.*
8. Back in the main home screen, under 'All Devices', the lock you have just added will appear.

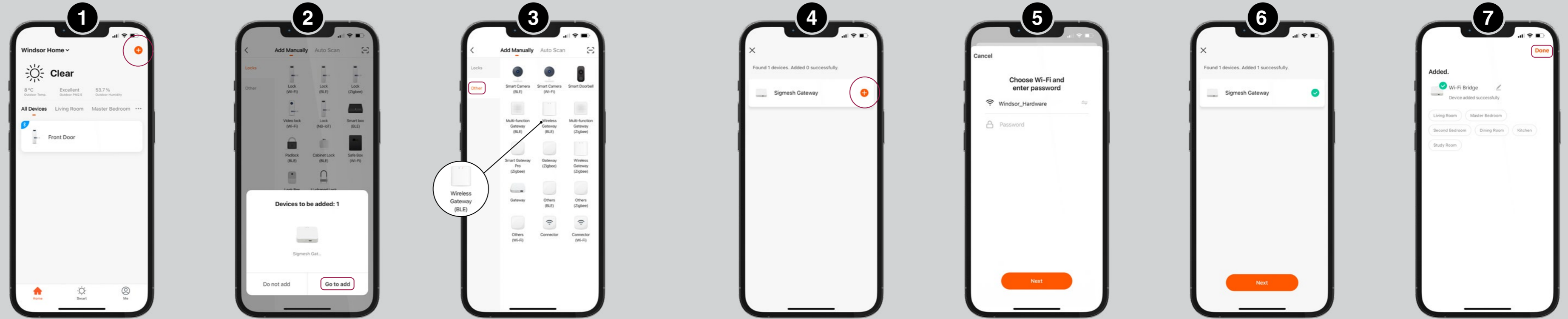

WI-FI BRIDGE INSTALLATION

Plug the Windsor Wi-Fi Bridge into a power source close to your Wi-Fi router and within Bluetooth range of the lock (estimate 8–12m). The bridge needs to show the red light flashing slowly. If this is not showing, press the reset button by the power jack for 6 seconds to reset.

Note: ensure your phone or tablet is connected to the same 2.4ghz Wi-Fi network (not 5G) as what the bridge will be connected to.

CONNECTING THE BRIDGE TO YOUR PHONE

1. In the main home screen, select the '+' (it may be in the centre of the screen depending on the device used).

2. The bridge should appear in a pop-up box 'Devices to be added' called 'Sigmesh Gateway'. Select 'Go to add'.
If this pop-up does not show up, refer to step 3 to add it manually. Otherwise proceed to step 4.

3. Select 'Other', then select 'Wireless Gateway (BLE)'. This will search and show up the Wi-Fi bridge in range.

4. Select the '+' on the 'Sigmesh Gateway' bridge device.

5. Add Wi-Fi details and password and select 'Next' and wait for this to connect.
> *Note: remember to connect to the same 2.4ghz Wi-Fi network (not 5G) as what your phone or tablet is connected to.*

6. Once connected the green tick will appear then select 'Next'.

7. You are now able to rename your Wi-Fi bridge by selecting the pen icon. Then select 'Done'.
> *Note: for information on integrating with your Smart Home system refer to pg.9.*
> *Note: you must now connect your lock to the Wi-Fi bridge please refer to the following page for instructions.*

* The Windsor Wi-Fi Bridge is sold separately as an optional extra if wanting to connect to Wi-Fi. This bridge can be used to connect multiple locks.

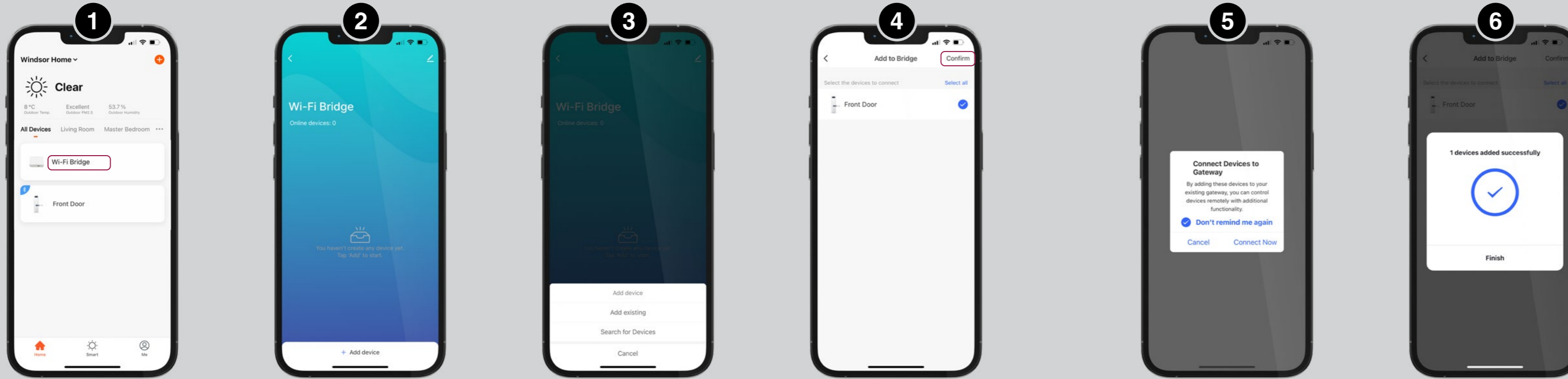

CONNECTING THE LOCK TO THE BRIDGE

1. Select your Wi-Fi bridge device in the main home screen.
2. In the blue bridge device screen select 'Add Device'.
3. Select 'Add Existing'.
4. Select the lock you would like to add to the bridge and select 'Confirm'.
5. We recommend ticking 'Don't remind me again' then select 'Connect Now'.
6. Your lock is now connected to Wi-Fi via the bridge device, access this via the home screen. You will be able to unlock and manage your device on standard mobile internet network from any location with reception.

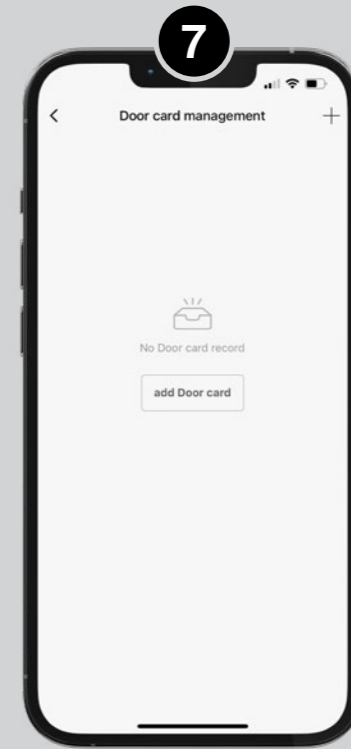
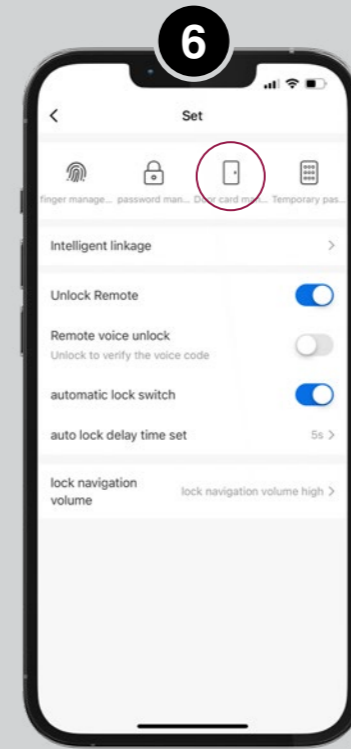
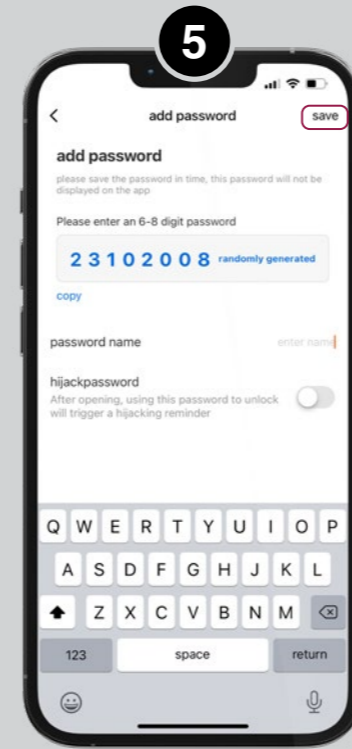
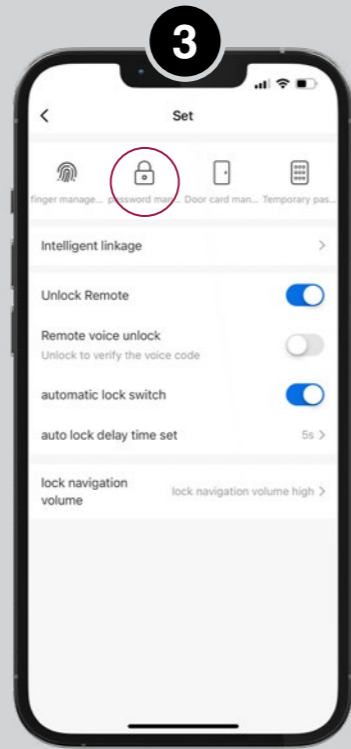
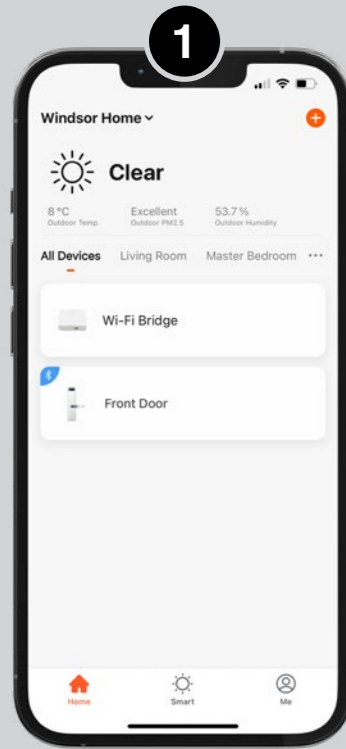

1. Select your lock in the main home screen.

2. From the blue lock screen select 'Set'.

> *Note: you may need to press the centre lock button to ensure Bluetooth is connected to the lock while making changes within the app.*

3. To add passwords select 'Password Management'.

> *Note: the fingerprint function is not available for use on the Windsor Smart Entry lock so you will not be able to use this function within the app.*

4. Select 'Add Password'.

5. Enter a 6–8 digit password and give it a name then select 'Save'.

6. To add cards select 'Door Card Management'.

7. Select 'Add Door Card'.

8. Select 'Start Collecting' then follow the prompts with your door card.

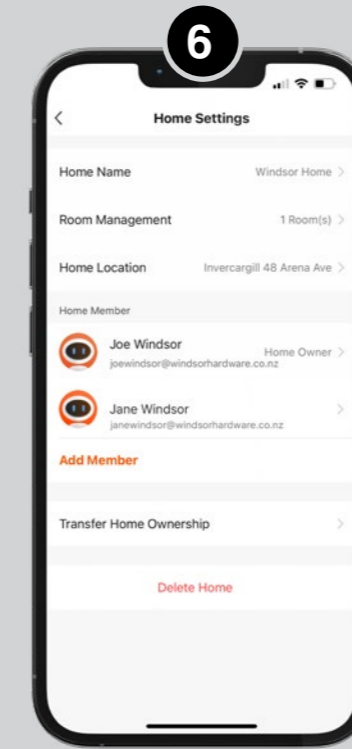
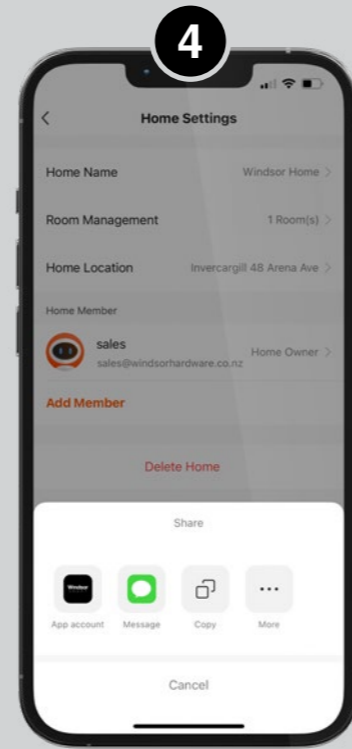
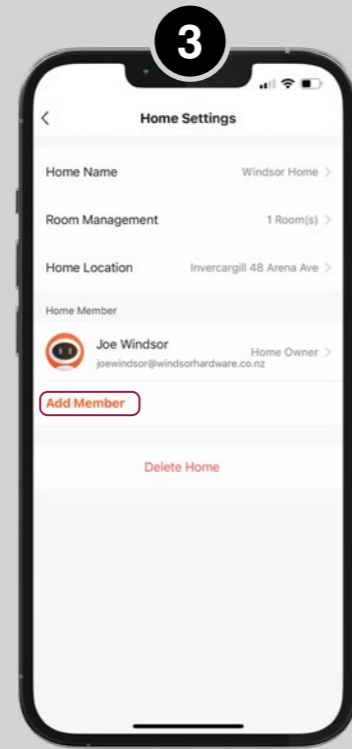
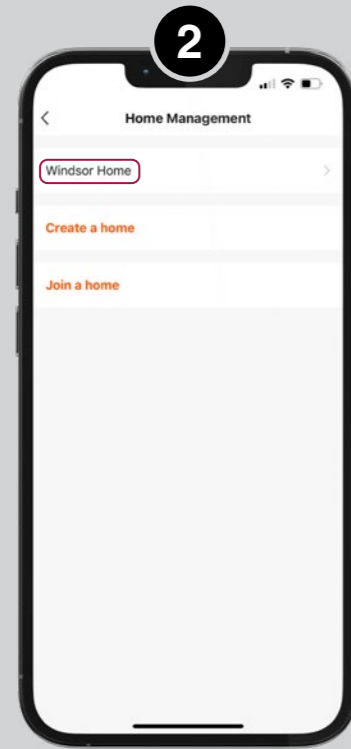
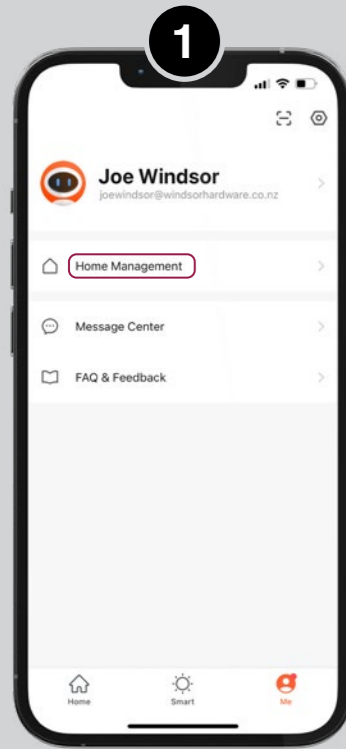

1. From the Me screen select 'Home Management'.

2. Select your home.

3. Under the Home Member section select 'Add Member'.
 > *Note: before adding other app users, it is recommended they first download the Windsor Smart app and have created an account.*

4. Select the method to share the details to the user.

5. Enter their details and select their family role, then select 'Save'. They will receive a notification to activate their access.

> *Note: for more information on family roles see pg. 38.*

6. They will now appear under the Home Member section of the Home Settings screen.

USING THE APP

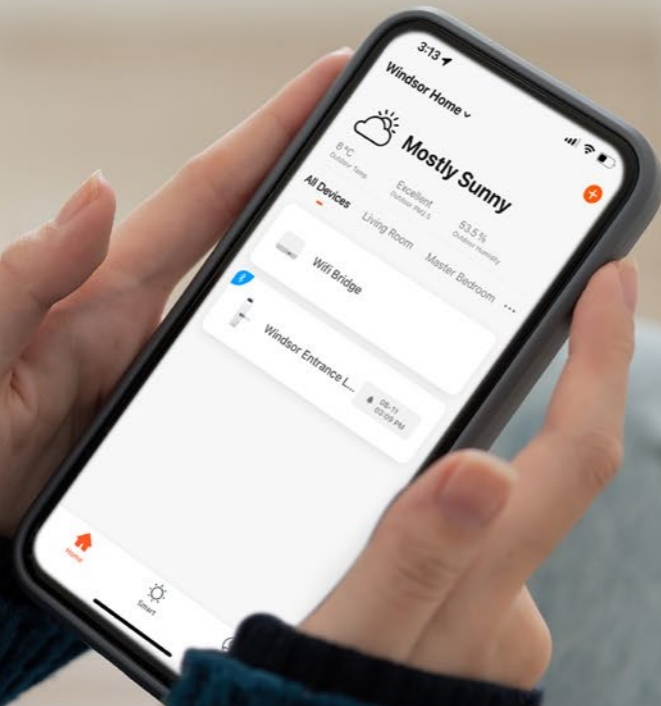

User Interface Introduction

Main Home Screen

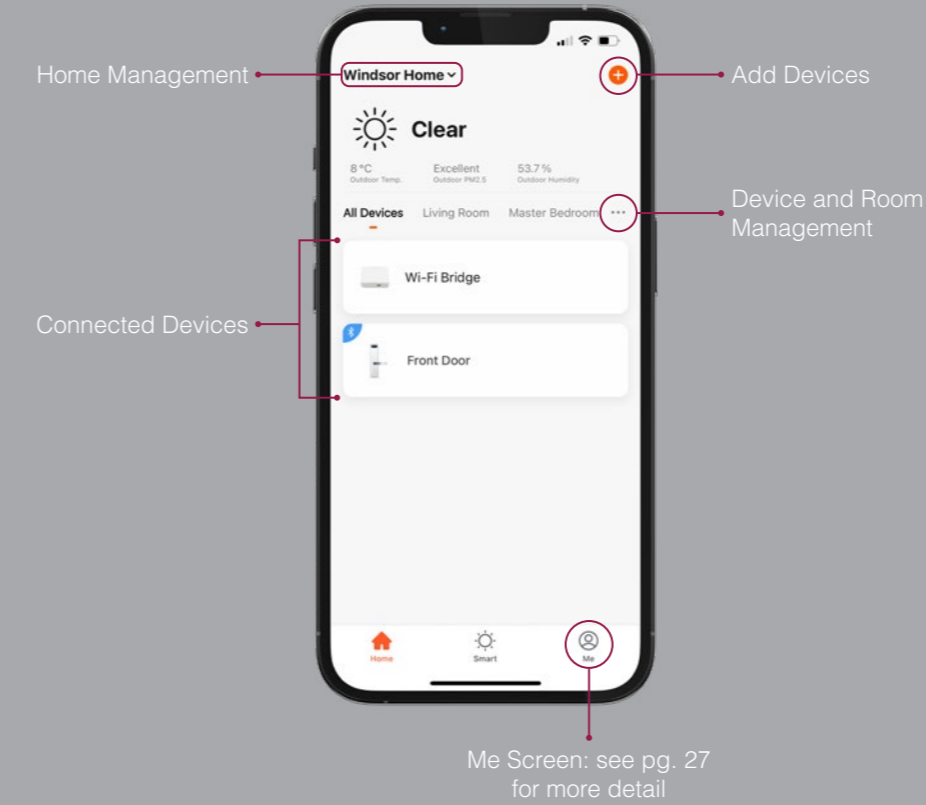

Main Lock Screen



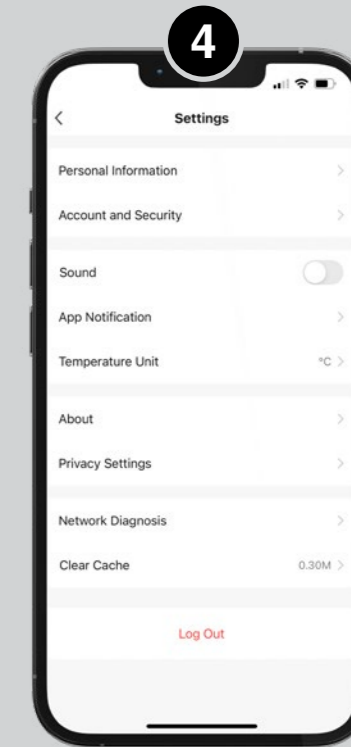
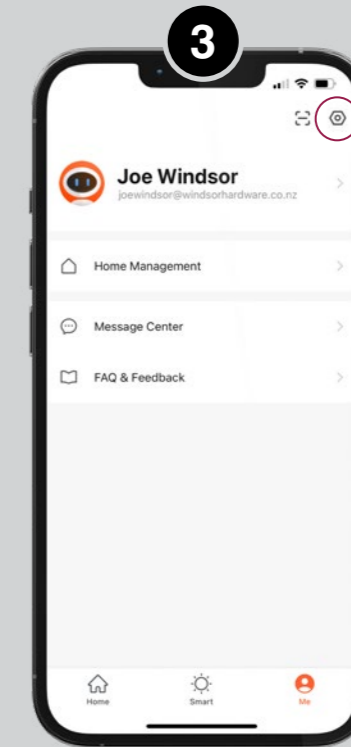
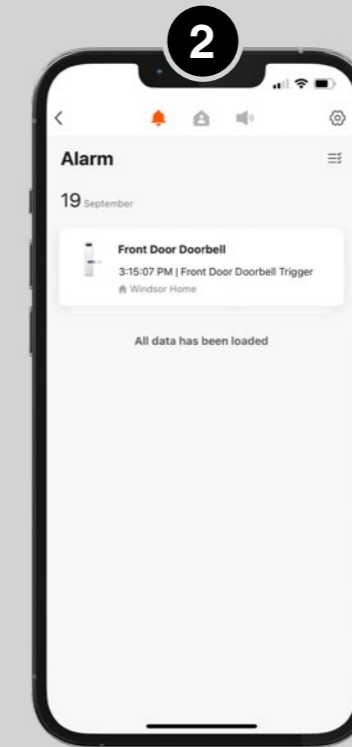
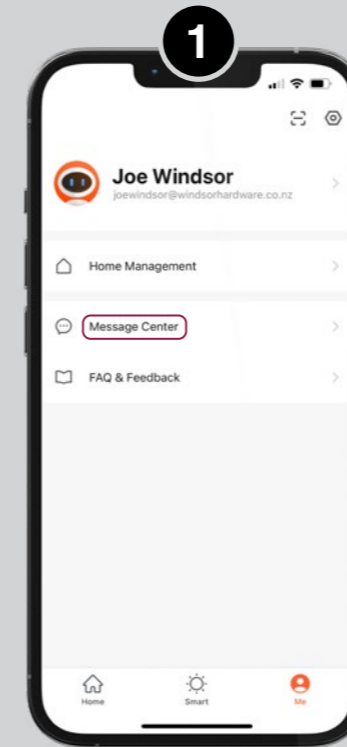
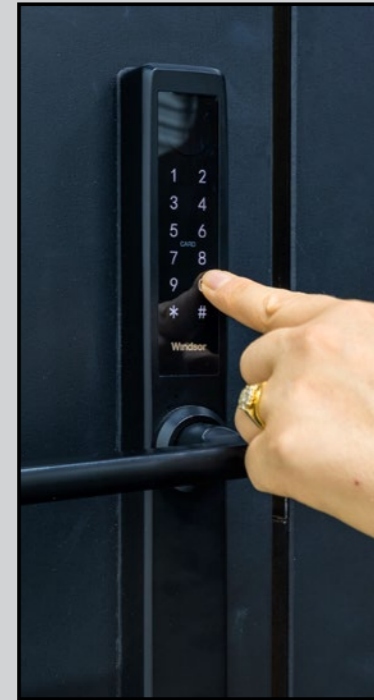
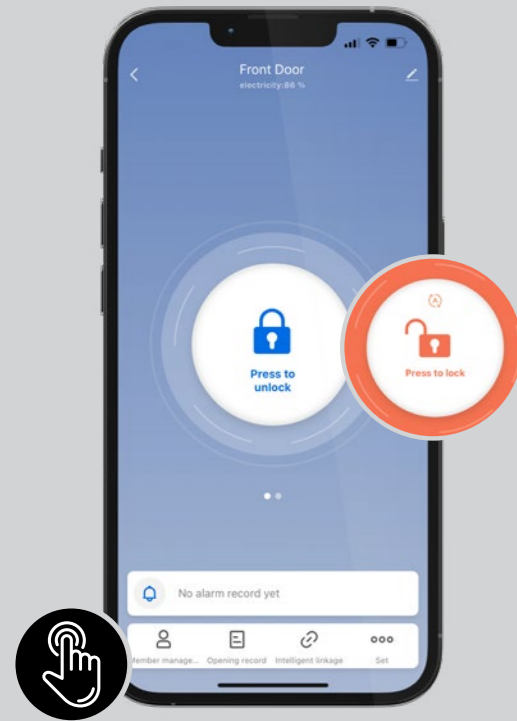

> To unlock using the app, in the blue lock screen, **press and hold** the large padlock icon for 1–2 seconds until the blue outer ring becomes orange as pictured above.*

> To unlock via the keypad, touch to activate, enter your code followed by '#'.*

> To unlock using the card, simply hold the card up to the centre of the keypad.*

> To unlock using the key, insert the key in the base of the lock unit on the front of the door. Turn to unlock (removing the key will lock the door).*

> *Note: if you leave the key in the lock body in the unlock position it will stay unlocked*

> *Note: for added security lift the lever up to throw the bolt, it will then retract the next time you unlock the door.*

* *Every time after unlocking, your door will remain unlocked for 5 seconds before self-locking again (unless you turn the automatic locking off). You can adjust the auto lock time after set up refer to pg. 30 for more information.*

1. In the Me screen, the settings and Message Centre can be accessed.

2. The Message Centre is where the alerts and notifications are located, as well as the usage data log and alarm settings.

The icons along the top navigation bar are for the below notifications:

- Alarm notifications
- Home messages
- Bulletin messages

3. While in the Me section select the cog icon to access your settings.

4. Here you can access your personal information, general app settings, privacy and cache settings.



BONUS FEATURES

Dynamic Code

Need someone to feed your pets while you're away but don't want to leave a key out?



1. From the blue lock screen, swipe left.

2. Select 'Get Dynamic Code'. This will generate a random code for the lock that will be valid for the next 5 minutes only before it expires.

3. You can simply copy and send the code to someone via text message or other messaging service.

Automatic Lock Switch

Want to quickly pop out and check the mail without the door locking behind you?

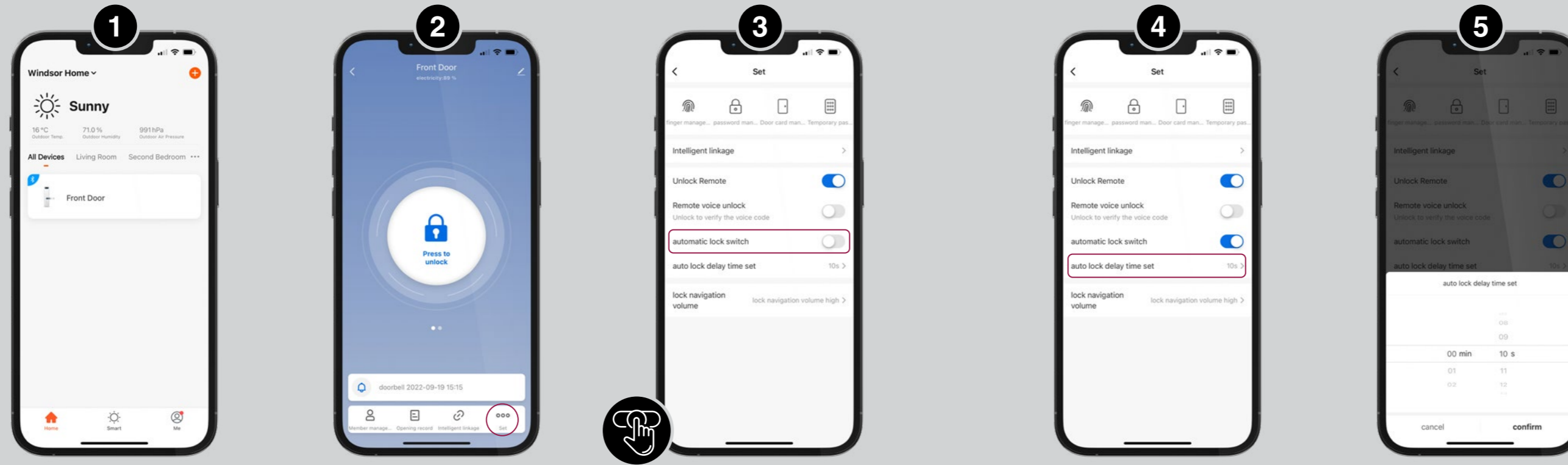

1. From the main home screen select your lock.
2. From the blue lock screen select 'Set'.
3. Toggle on the automatic lock switch.
4. Once the automatic lock switch is on, select 'auto lock delay time set' to set the preferred delay time.
5. Once you have set the delay time by selecting 'Confirm', the lock will go into passage mode for the set amount of time allowing you to complete a task e.g. getting the mail in.

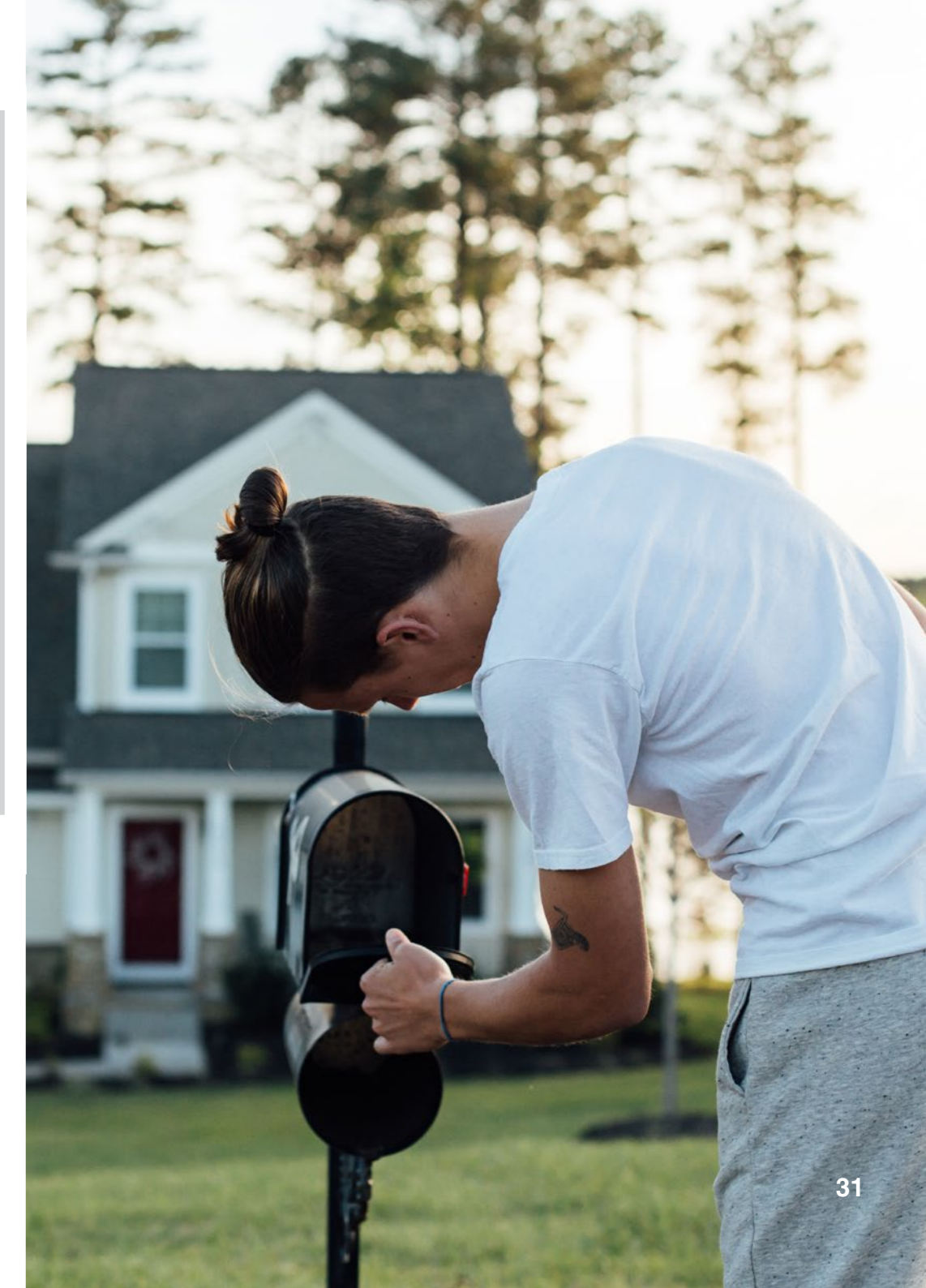

Passage Mode

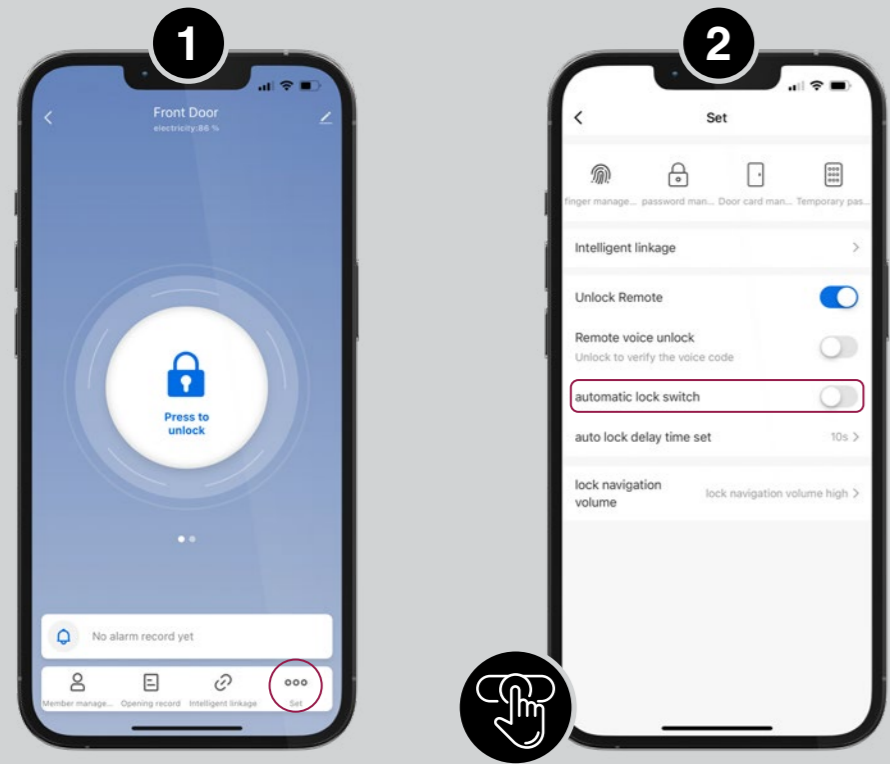

Freedom to give that indoor outdoor flow without having to unlock the door frequently.

1. From the blue lock screen select 'Set'.
 - > *Note: when the lock is in passage mode you can also hold down the '*' key and lock it from the keypad.*
2. Toggle off the 'automatic lock switch' then unlock the door using any unlock method, this will then activate passage mode.
 - > *Note: to deactivate passage mode simple toggle the switch back on.*



Opening Record

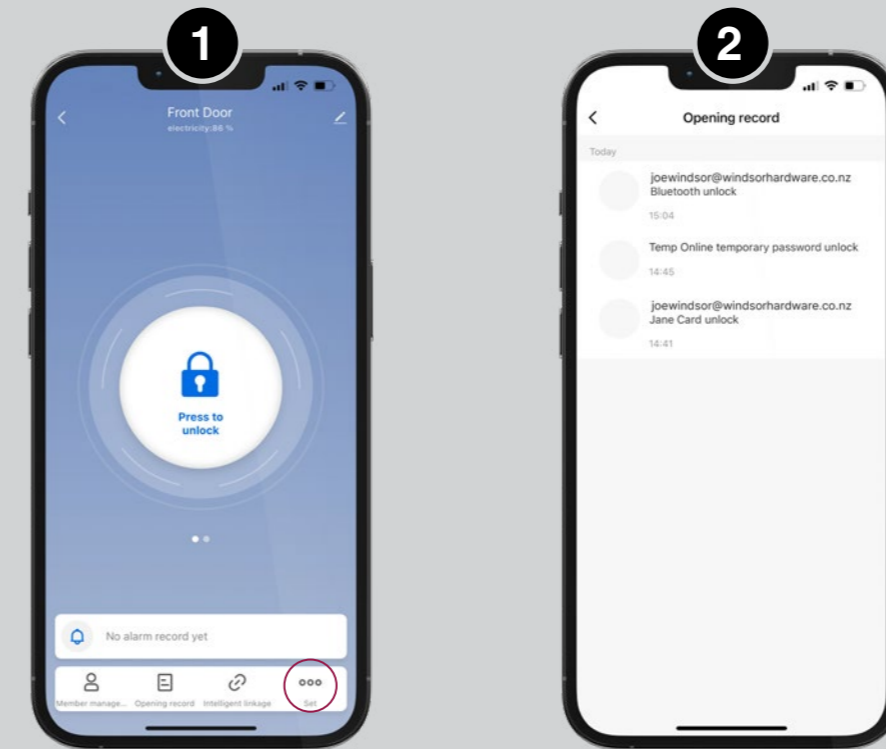

Keep track of who is coming and going in your home with the opening record feature.

1. From the blue lock screen select 'Set'.
2. The records are displayed in real time and chronological order and are labelled as the assigned username or unique identifier e.g. Plumber/Housesitter.
 - > *Note: if using Bluetooth the records will only show when you are within Bluetooth range and connected to the lock.*



One Time Code

Have a plumber calling in to fix your tap while you're at work? Save the dash home to meet them and unlock the door.



1. From the blue lock screen select 'Set'.

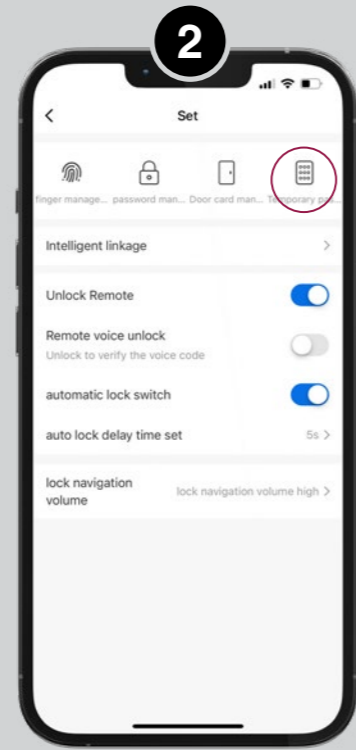

2. In the Set screen select 'Temporary Passcode'.

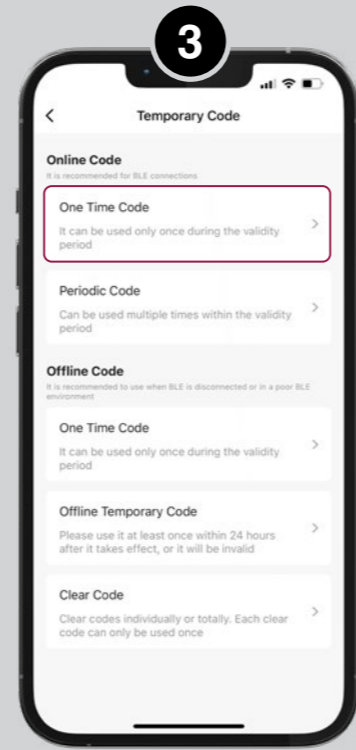

3. In the Temporary Code screen select 'One Time Code'.

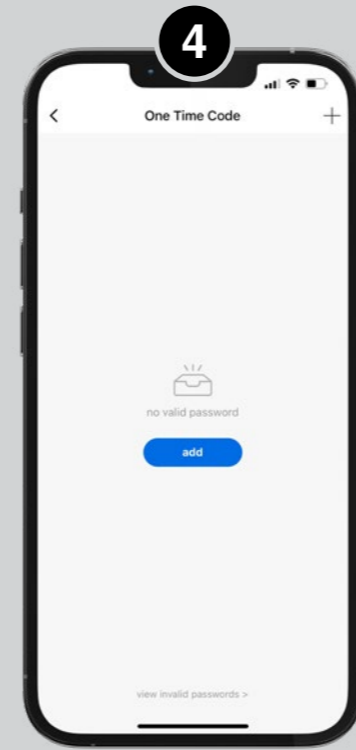

4. In the One Time Code screen select 'Add'.

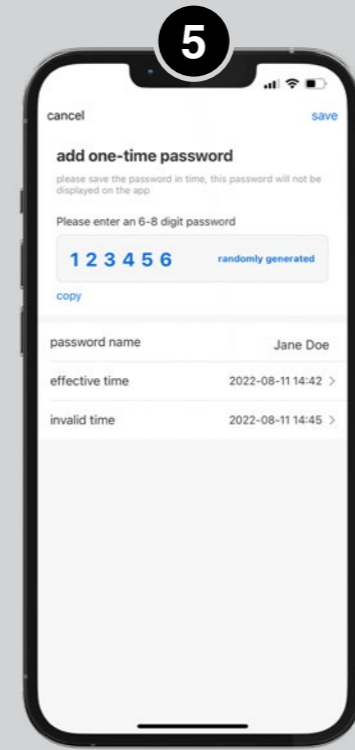

5. The app can randomly generate a password or you may create your own. Name the password with a unique identifier e.g. Plumber/Housesitter. Ensure you set the time period the code will be valid for. If the code is used outside of that timeframe it will be deactivated.

> *Note: remember this code is valid for one use only.*



Periodic Code

Grant an Airbnb guest access for a short period of time with a definitive start and end date.



1. From the blue lock screen select 'Set'.

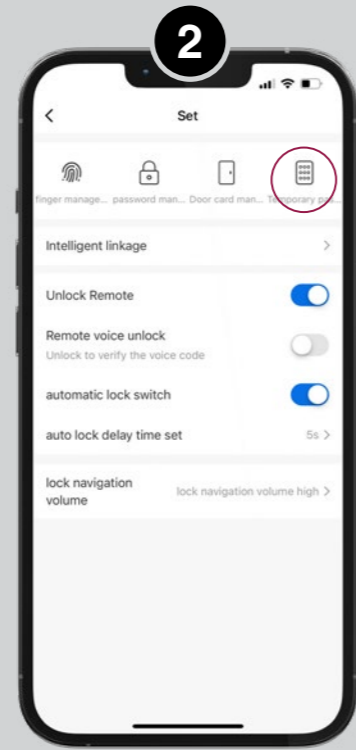

2. In the Set screen select 'Temporary Passcode'.

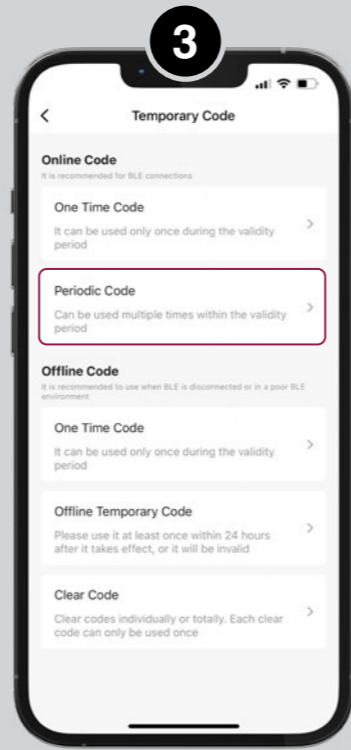

3. In the Temporary Code screen select 'Periodic Code'.

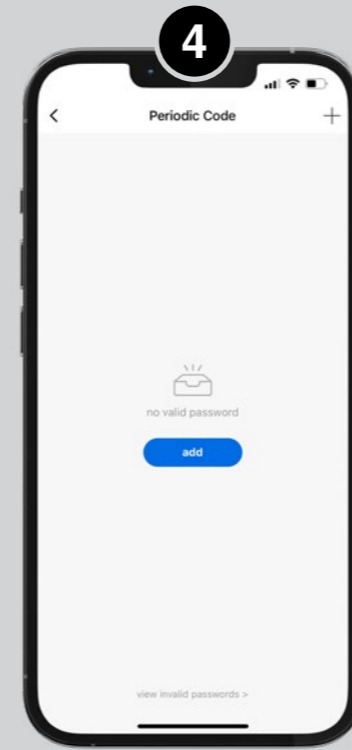

4. In the Periodic Code screen select 'Add'.

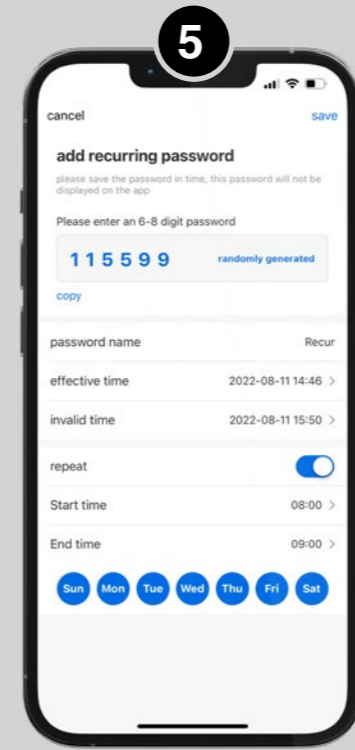

5. The app can randomly generate a password or you may create your own. Name the password with an unique identifier e.g. Airbnb guest name. Ensure you set the time period it will be valid for, if it is used outside of that timeframe the code will be deactivated. Once set up, this code may be used as many times as required within the assigned timeframe.



Changing Home Roles

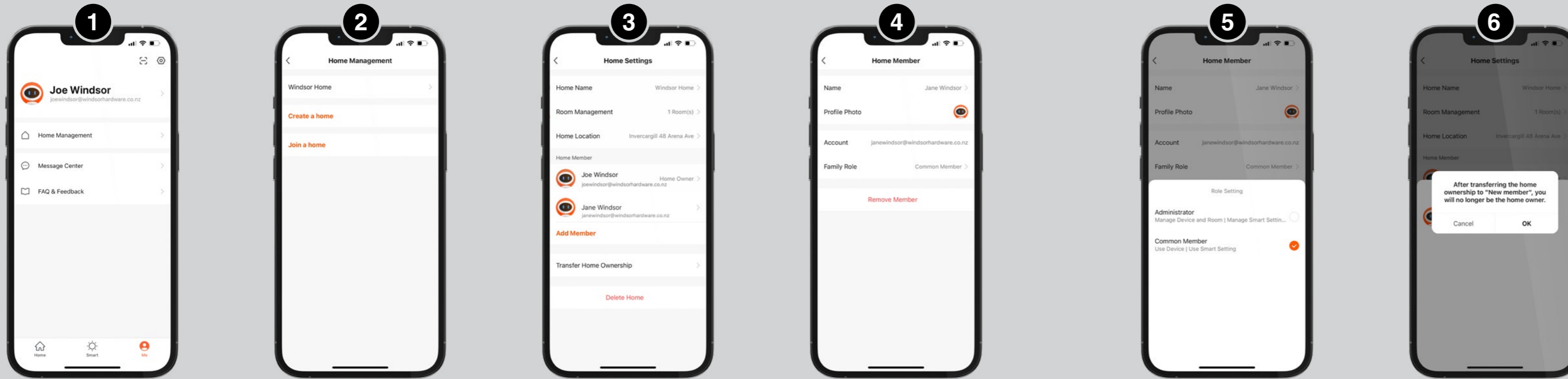

Have a new flatmate moving in and need to add a new person to your home?

CHANGING HOME MEMBER ROLES

1. In the Me screen select 'Home Management'.
2. Select the specific home (if more than one unit is managed on the app).
3. In the Home Settings screen, select the member you would like change the status or adjust the permissions for.
4. Select 'Family Role' to change permissions or select 'Remove Member' to remove a user from your home.
5. After selecting 'Family Role' you can change the user to either an 'Administrator' or 'Common Member'.
 - > *Note: to change home ownership to a different user, you will need to change their status to 'Administrator' first.*

CHANGING HOME OWNERSHIP

Refer back to the Home Settings screen in step 3, it will show 'Transfer Home Ownership' under the Home Member section. Select this and change full ownership rights, management and permissions to the user you select.

Note: the new owner will get a notification advising the home ownership change.



Removing Devices

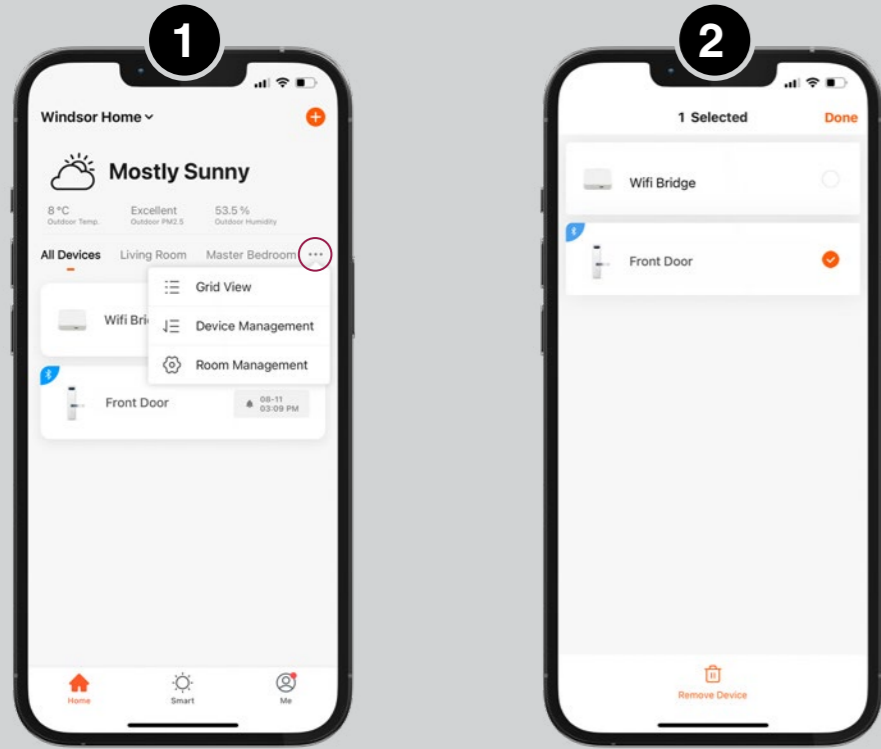

1. From the main home screen, select the three dot menu, then select 'Device Management'.

2. Select the device to delete and 'Remove Device' at the bottom of the page.

Factory Resetting Device

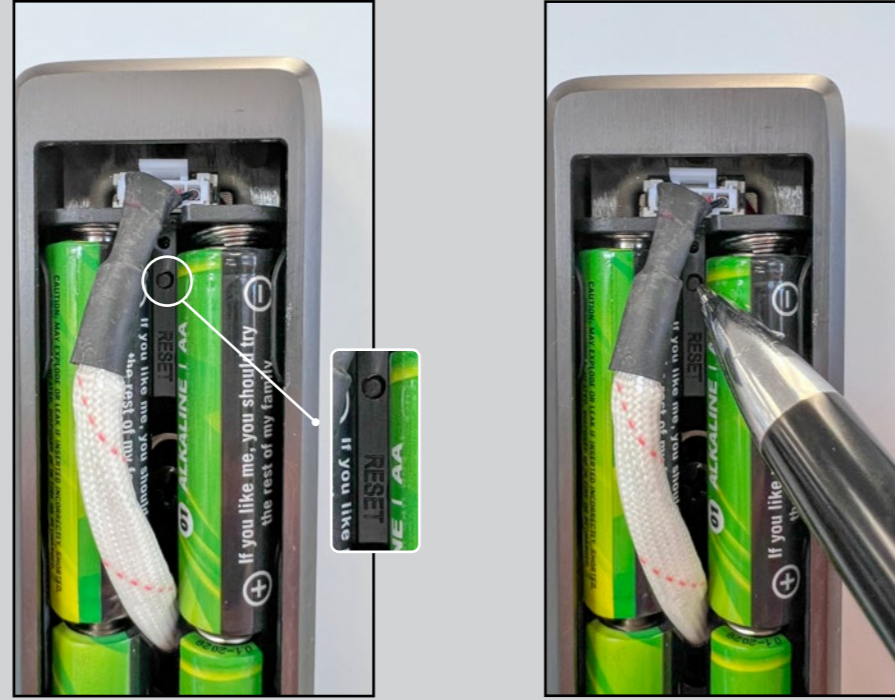

1. On the lock itself, remove the battery cover on the back and locate the reset button behind the wires.

2. With the tip of a pen, press and hold the reset button for 6 seconds and wait for verbal confirmation from the lock itself.

Frequently Asked Questions

QUESTION	ANSWER
How can you read opening records?	In the records of the main interface.
Why can I not unlock the lock after enabling the passage mode?	You need to perform an unlock verification using any lock/unlock method, then the passage mode will take effect. Refer to Step 2 on pg. 32 for more information.
After installation the keypad screen does not respond.	<ul style="list-style-type: none"> a) In this case, first check that the positive and negative electrodes of the battery have been installed the correct orientation and whether the batteries have enough power. b) Remove the back panel and see if it is connected properly. c) Remove the lock, check whether the wires of the lock body are squeezed, and then re-wire.
Why does the smart lock use a lot of power?	<ul style="list-style-type: none"> a) Large standby power consumption b) Short circuit
There is no response when pushing the handle on the outside of the door, however it unlocks normally on the inside of the door. The verification is normal, and the motor is normal.	It may be the incorrect direction of the small triangle on the spindle shaft. Please refer to Step 5 on pg. 4.
After how many times of entering the wrong passcode will the keypad lock itself?	If you enter the wrong passcode more than 5 times in a row.
After entering the wrong passcode 5 times how long will the keypad lock for?	The keypad will lock for 90 seconds.
Can you program your lock remotely?	Yes, if it's connected to a Wi-Fi bridge.
How do I know my Windsor Wi-Fi Bridge is working?	Turn off your Wi-Fi on your phone and do a test lock/unlock, if it responds then Wi-Fi bridge.
Why does the bolt not throw when I lock using the app?	The bolt only throws by manually lifting the lever upward. The app disables and enables the latch only.
How many passwords can a lock have?	Maximum of 100 passwords.
How many users can a lock have?	Maximum of 100 users.
How will I know if the lock needs an update?	When opening the app if an update is needed a pop up will appear.
Can I adjust the screen brightness?	No the brightness cannot be adjusted.

NZ 0800 607 028
AU 1800 841 643

sales@windsorhardware.co.nz
windsorhardware.co.nz
windsorhardware.com.au



Windsor
ARCHITECTURAL HARDWARE